

INSTRUCTION MANUAL FOR



RUGER® PC CHARGER™



– Rugged, Reliable Firearms® –



**READ THE INSTRUCTIONS AND
WARNINGS IN THIS MANUAL CAREFULLY
BEFORE USING THIS FIREARM**

© 2022 Sturm, Ruger & Co., Inc.

This manual may not be reproduced in whole or in part without the express written permission of Sturm, Ruger & Co., Inc.

**For Service on This Model Please Call:
(336) 949-5200 (See p. 45)**

THIS INSTRUCTION MANUAL SHOULD ALWAYS ACCOMPANY THIS FIREARM AND BE
TRANSFERRED WITH IT UPON CHANGE OF OWNERSHIP, OR WHEN THE FIREARM IS LOANED
OR PRESENTED TO ANOTHER PERSON

RUGER.COM

PCC-9CP 4/2022 R4

State-By-State Warnings

Certain states require by law that their own specified warning notices in larger-than-normal type be conspicuously included by the manufacturer, distributor or retailer with firearms sold in that state. Sturm, Ruger & Co., Inc. sells its products in compliance with applicable laws and regulations. Because our products may be sold in these states, we include the following:

California:

WARNING

“Firearms must be handled responsibly and securely stored to prevent access by children and other unauthorized users. California has strict laws pertaining to firearms, and you may be fined or imprisoned if you fail to comply with them. Visit the Web site of the California Attorney General at <https://oag.ca.gov/firearms> for information on firearm laws applicable to you and how you can comply.

Prevent child access by always keeping guns locked away and unloaded when not in use. If you keep a loaded firearm where a child obtains and improperly uses it, you may be fined or sent to prison.

If you or someone you know is contemplating suicide, please call the national suicide prevention lifeline at 1-800-273-TALK (8255).”

ADVERTENCIA

“Las armas de fuego deben manipularse de manera responsable y segura para evitar el acceso de niños y otros usuarios no autorizados. California tiene leyes estrictas relacionadas con armas de fuego, y usted puede ser multado o encarcelado si no las cumple. Visite el sitio web del Procurador General de California en <https://oag.ca.gov/firearms> para obtener información sobre las leyes de armas de fuego que le son aplicables y cómo puede cumplirlas.

A los niños los atraen las armas de fuego y las pueden hacer funcionar. Ellos pueden causarse lesiones graves y la muerte. Evite que los niños tengan acceso a las armas de fuego guardándolas siempre con llave y descargadas cuando no las esté utilizando. Si usted tiene un arma de fuego cargada en un lugar en que un niño tiene acceso a ella y la usa indebidamente, le pueden dar una multa o enviarlo a la cárcel.

Si usted o alguien que conoce está pensando en suicidarse, llame a la línea nacional de prevención del suicidio al 1-800-273-TALK (8255).”

Connecticut:

“UNLAWFUL STORAGE OF A LOADED FIREARM MAY RESULT IN IMPRISONMENT OR FINE.”

Florida:

“IT IS UNLAWFUL, AND PUNISHABLE BY IMPRISONMENT AND FINE, FOR ANY ADULT TO STORE OR LEAVE A FIREARM IN ANY PLACE WITHIN THE REACH OR EASY ACCESS OF A MINOR UNDER 18 YEARS OF AGE OR TO KNOWINGLY SELL OR OTHERWISE TRANSFER OWNERSHIP OR POSSESSION OF A FIREARM TO A MINOR OR A PERSON OF UNSOUND MIND.”

Maine:

“ENDANGERING THE WELFARE OF A CHILD IS A CRIME. IF YOU LEAVE A FIREARM AND AMMUNITION WITHIN EASY ACCESS OF A CHILD, YOU MAY BE SUBJECT TO FINE, IMPRISONMENT OR BOTH. KEEP FIREARMS AND AMMUNITION SEPARATE. KEEP FIREARMS AND AMMUNITION LOCKED UP. USE TRIGGER LOCKS.”

Maryland:

“WARNING: Children can operate firearms which may cause death or serious injury. It is a crime to store or leave a loaded firearm in any location where an individual knew or should have known that an unsupervised minor would gain access to the firearm. Store your firearm responsibly!”

Massachusetts:

“WARNING FROM THE MASSACHUSETTS ATTORNEY GENERAL: This handgun is not equipped with a device that fully blocks use by unauthorized users. More than 200,000 firearms like this one are stolen from their owners every year in the United States. In addition, there are more than a thousand suicides each year by younger children and teenagers who get access to firearms. Hundreds more die from accidental discharge. It is likely that many more children sustain serious wounds, or inflict such wounds accidentally on others. In order to limit the chance of such misuse, it is imperative that you keep this weapon locked in a secure place and take other steps necessary to limit the possibility of theft or accident. Failure to take reasonable preventive steps may result in innocent lives being lost, and in some circumstances may result in your liability for these deaths.”

“IT IS UNLAWFUL TO STORE OR KEEP A FIREARM, RIFLE, SHOTGUN OR MACHINE GUN IN ANY PLACE UNLESS THAT WEAPON IS EQUIPPED WITH A TAMPER-RESISTANT SAFETY DEVICE OR IS STORED OR KEPT IN A SECURELY LOCKED CONTAINER.”

New Jersey:

“IT IS A CRIMINAL OFFENSE TO LEAVE A LOADED FIREARM WITHIN EASY ACCESS OF A MINOR.”

New York:

“THE USE OF A LOCKING DEVICE OR SAFETY LOCK IS ONLY ONE ASPECT OF RESPONSIBLE FIREARM STORAGE. FOR INCREASED SAFETY, FIREARMS SHOULD BE STORED UNLOADED AND LOCKED IN A LOCATION THAT IS BOTH SEPARATE FROM THEIR AMMUNITION AND INACCESSIBLE TO CHILDREN AND UNAUTHORIZED PERSONS.”

North Carolina:

“IT IS UNLAWFUL TO STORE OR LEAVE A FIREARM THAT CAN BE DISCHARGED IN A MANNER THAT A REASONABLE PERSON SHOULD KNOW IS ACCESSIBLE TO A MINOR.”

Texas:

“IT IS UNLAWFUL TO STORE, TRANSPORT, OR ABANDON AN UNSECURED FIREARM IN A PLACE WHERE CHILDREN ARE LIKELY TO BE AND CAN OBTAIN ACCESS TO THE FIREARM.”

Wisconsin:

“IF YOU LEAVE A LOADED FIREARM WITHIN THE REACH OR EASY ACCESS OF A CHILD YOU MAY BE FINED OR IMPRISONED OR BOTH IF THE CHILD IMPROPERLY DISCHARGES, POSSESSES, OR EXHIBITS THE FIREARM.”

* * * * *

Please check with your licensed retailer or state police for additional warnings which may be required by local law or regulation. Such regulations change constantly, and local authorities are in the best position to advise you on such legal matters.

FIREARMS SAFETY IS YOUR RESPONSIBILITY
SAFETY MUST BE THE FIRST AND CONSTANT
CONSIDERATION OF EVERY PERSON WHO HANDLES
FIREARMS AND AMMUNITION.

This instruction manual is designed to assist you in learning how to use and care for your **RUGER® PC CHARGER™** properly. Please contact us if you have any questions.

Only when you are certain you fully understand the manual and can properly carry out its instructions should you practice loading, unloading, etc. with live ammunition. If you have any doubts about your ability to handle or use a particular type of firearm safely, you should seek supervised instruction. Such personalized instruction often is available from local firearm retailers, gun clubs or police departments. If none of these sources can help, visit nra.org or write to the following address:

National Rifle Association
11250 Waples Mill Road
Fairfax, VA 22030-7400

The person possessing a firearm has a full-time job. You cannot guess; you cannot forget. You must know how to use your firearm safely. **Do not use any firearm without having a complete understanding of its particular characteristics and safe use.** Remember: There is no such thing as a foolproof firearm.

TABLE OF CONTENTS

	Page
State-By-State Warnings	2
Nomenclature	8
Locking Device Installation Instructions	9
General Information and Mechanical Characteristics	11
Thread Protector (On Models So Equipped)	13
The Bolt Stop	14
Magazine Well Removal & Replacement	15
Reversible Magazine Release	19
Reversible Charging Handle	21
Operation of Safety	22
Ammunition	23
Magazines	24
Loading the Magazine	24
To Load and Fire (With Magazine)	24
To Load and Fire (Without Magazine)	27
To Unload	27
To Extract and Eject a Chambered Cartridge	29
To Clear a Malfunction (“Jam” or “Misfire”)	29
To Minimize Malfunctions (“Jams” or “Misfires”)	30
Disassembly	32
Reassembly	36
Barrel/Handguard Assembly	40
Check Your Pistol’s Function	41
Magazine Inspection and Care	42
Care and Cleaning	42
Storage	44
Service and Parts Policy	45
Shipping Firearms for Repair	45
Ordering Parts	46
Parts Lists	47
Exploded Views	49 - 53
The Basic Rules of Safe Firearms Handling	54
Warranty Information	60

“RUGER” is a registered U.S. trademark.



WARNINGS OF GREAT IMPORTANCE ARE FOUND ON THE FOLLOWING PAGES:

Locking Devices	9	Handling	26
Alterations	11	Unloading	27
Hand Stop Usage	12	Malfunctions	31
National Firearms Act	13	Disassembly	31
Muzzle Devices	13	Lubrication	43
Manual Safety	22	Storage	44
Ammunition	23	Shipping	45
Lead Exposure	23	Parts Purchasers	46
Firing	25		

OTHER CAUTIONS AND WARNINGS APPEAR THROUGHOUT THE MANUAL.

NOMENCLATURE

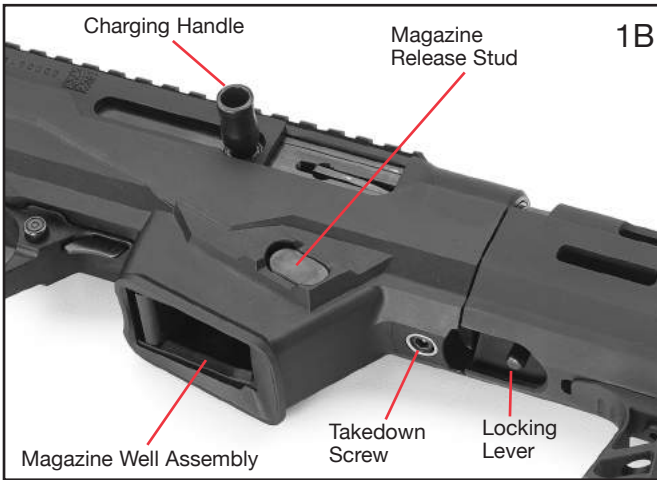
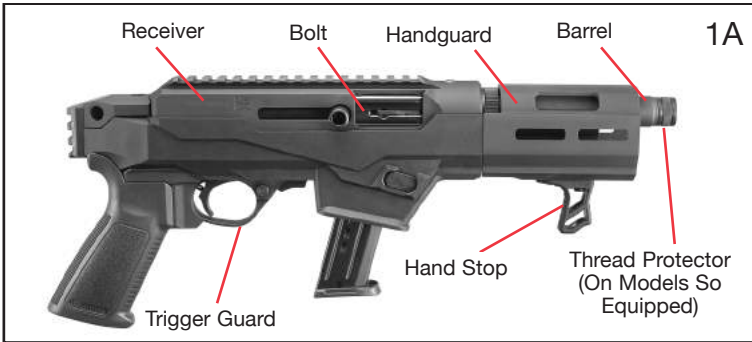

Figures 1A, B, C. In these illustrations the frequently used operating components are identified. Note that the safety is fully depressed into the left side of the trigger guard (and fully protruding from the right side, which is not visible) and is therefore in its "ON" (safe) position.

LOCKING DEVICE INSTALLATION INSTRUCTIONS



WARNING – USE OF LOCKING DEVICES



**Do not store keys
in lock.**

- Always keep your firearm pointed in a safe direction, including when you are installing or removing your locking device.
- Always verify that your firearm is completely **unloaded** before installing your locking device.
- Do **not** install locking devices in the trigger guard; always keep your fingers and locking device outside the trigger guard during device installation and removal.
- Store firearms, ammunition and keys separately and securely, away from children and careless adults; do **not** store your firearm with the keys in the locking device.
- Do not attempt to work the action of your firearm with the locking device in place; this may damage your firearm.
- While locking devices are an important aid to security measures, they are not a substitute for safe firearm handling and proper storage. Remember that any mechanical device can be bypassed with enough time, knowledge, determination and equipment.

**LOCKING DEVICES MUST BE
USED SAFELY AND
RESPONSIBLY**

It is important to use the locking device on your Ruger® firearm when the firearm is stored or immediate use is not planned.

Keep the muzzle pointed in a safe direction and your fingers outside the trigger guard at all times!

1. Remove the magazine. Be sure the firearm and its magazine are completely unloaded and contain no cartridges or cartridge cases!
2. Open the action completely, and verify that the firearm is completely unloaded and contains no cartridges or cartridge cases. Use the bolt stop to keep the action open.
3. Remove the barrel/handguard assembly as described in the “Disassembly” section, p. 32.
4. Insert the cable directly into the receiver as shown in Figure 2.
5. To lock: With the key turned to the farthest clockwise position, insert the loose end of the cable into the lock. Turn the key counterclockwise and remove the key.
6. Once the lock is securely closed, pull firmly on the lock to test the connection and be sure it is locked. **Do not leave or store your firearm with the key in the lock!** Store your locked, unloaded firearm and the key in secure, separate locations, away from ammunition, children, and unauthorized adults.

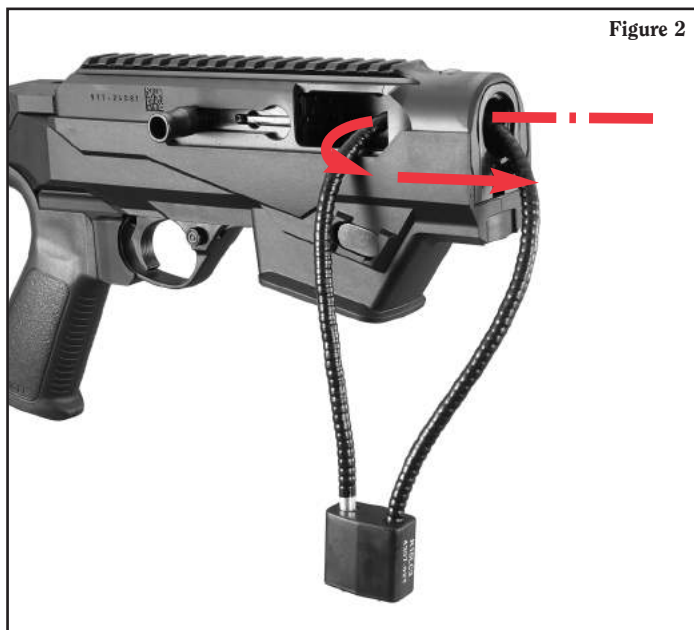

Correct installation of the lock on a
RUGER® PC CHARGER™.

**FIREARMS ARE DANGEROUS WEAPONS.
READ THE INSTRUCTIONS AND WARNINGS IN THIS
MANUAL THOROUGHLY AND CAREFULLY BEFORE USING.**

 WARNING-ALTERATIONS	
	This product was designed to function properly in its original condition. Alterations can make it unsafe. Do not alter any part or add or substitute parts not made or sold by Sturm, Ruger & Co., Inc.
	DO NOT ALTER ANY FIREARM

GENERAL INFORMATION AND MECHANICAL CHARACTERISTICS

The **RUGER® PC CHARGER™** is an autoloading pistol chambered for the 9mm Luger (Parabellum) cartridge. Use only ammunition of the correct caliber. The **PC CHARGER™** is “blowback” operated and uses standard **RUGER® SECURITY-9®** or **SR9®** pistol magazines with the factory-installed magazine well. Retracting the charging handle cocks the internal hammer and compresses the recoil spring. When the bolt is manually released, it moves forward (driven by the recoil spring), strips a cartridge from the magazine (if a loaded magazine is in place) and chambers the cartridge. The bolt is held against the chambered cartridge by the recoil spring.

When the trigger is pulled, the hammer is released and strikes the firing pin. The firing pin indents the cartridge primer and ignites the priming compound. This ignites the powder in the cartridge case and a great volume of gas is instantly generated, which acts on the interior of the cartridge case in all directions.

 WARNING – PISTOL MAY FIRE WITH MAGAZINE REMOVED	
The pistol will fire if there is a cartridge in the chamber and the trigger is pulled, whether or not there is a magazine in place! Removing the magazine does not unload the pistol. Never assume the pistol is unloaded. Visually inspect the chamber and the magazine each time the pistol is handled to be certain there are no cartridges in either.	

Because the bullet offers the least resistance, it moves out of the cartridge case and exits the muzzle. The bolt then moves rearward automatically, extracting and ejecting the fired cartridge case, and at the same time cocking the hammer and compressing the recoil spring, etc., as described above. Once the trigger is released, the pistol is ready to fire again.

Each time the trigger is pulled and released, the same cycle is repeated until there are no more cartridges in the magazine or in the chamber.

The **RUGER® PC CHARGER™** features easy takedown for quick separation of the barrel/forend assembly from the action for ease of transportation and storage. Simple reassembly allows for a secure connection of the barrel/forend assembly and action and returns the firearm to zero, even when receiver mounted optics are used, ensuring consistent accuracy. See page 40 for information about the “Barrel/Handguard Assembly.”

NOTE: The receiver-mounted, Picatinny-style rail is designed to accommodate most optics and optic mounts intended for use with Picatinny/MIL-STD 1913 rails. However, due to reduced clearance between the top of the receiver and the bottom of the optics rail, optics and optic mounts that extend more than .275" below the top of the rail may not fit the **PC CHARGER™**. Ensure that the optic or optic mount you intend to use does not extend more than .275" below the top of the Picatinny-style rail when installed.

The **PC CHARGER™** does not include factory-installed front or rear sights.

 WARNING – HAND STOP USAGE	
	<p>The PC Charger™ comes equipped with a hand stop mounted on the lower portion of the handguard. The hand stop helps ensure that you always keep your support hand behind the muzzle</p> <p>DO NOT ATTEMPT TO GRASP THE HAND STOP AS A GRIP WITH YOUR SUPPORT HAND, AND ALWAYS MAKE SURE THAT YOUR SUPPORT HAND REMAINS BEHIND THE MUZZLE.</p>
KEEP HANDS AWAY FROM MUZZLE	

The **RUGER® PC CHARGER™**, as equipped from the factory is not regulated by the National Firearms Act (“NFA”). However, alterations to the pistol (including installation of a stock or vertical fore-grip) may reclassify the pistol as an NFA-regulated firearm. For more information about the NFA, please visit ATF.gov.



WARNING – NATIONAL FIREARMS ACT

The National Firearms Act, 26 U.S.C. Chapter 53, prohibits the unauthorized making, manufacture, and possession of certain firearms, including:

- 1) A rifle having a barrel of less than 16 inches in length;
- 2) A weapon made from a rifle if such weapon as modified has an overall length of less than 26 inches or a barrel of less than 16 inches in length; and
- 3) A handgun with a secondary vertical fore-grip installed.

Unauthorized possession, making, or manufacture of any NFA-regulated firearm is a felony under the NFA and may also be illegal under state or local law.

All users should familiarize themselves with and comply with all federal, state, and local laws and regulations regarding the possession and use of firearms.

THREAD PROTECTOR (On Models So Equipped)

The **RUGER® PC CHARGER™** pistol comes equipped with a ½”-28 threaded muzzle and corresponding thread protector. The thread protector is retained in position by a factory-installed O-Ring when manually tightened (see Figure 3). If any other muzzle device is used other than the factory-provided thread protector, the O-Ring must be removed. Removing the O-Ring ensures that:

1. muzzle devices shoulder out on the barrel; and
2. muzzle devices mount concentrically to the bore.

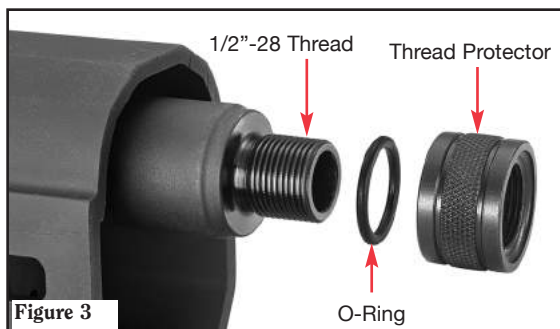

Figure 3



WARNING – MUZZLE DEVICES

Ensure that all muzzle devices installed on the **PC CHARGER™** are intended for use on firearms chambered in the caliber marked on the barrel. Failure to do so may result in injury and damage to your pistol.

USE MUZZLE DEVICES OF THE CORRECT CALIBER

THE BOLT STOP

The bolt stop is located in the forward section of the trigger guard (see Figure 1C, p. 8). The bolt stop is the manually operated means of retaining the bolt in the rearward (open) position. When the bolt is locked open, the pistol is in an inoperative, safe condition for inspection of the chamber, cleaning, etc.

To hold the bolt open: Retract the charging handle to its extreme rearward position and, while holding it there, press up on the bolt stop. Release pressure on the charging handle and it will move forward a fraction of an inch and then be held in its open position by the bolt stop (see Figure 4a).



WARNING – JARRING PISTOL CAN RELEASE BOLT AND CHAMBER A ROUND

The bolt stop is **NOT** a safety device. It should not be used to hold the bolt back when there are cartridges in the magazine. A slight jar to the butt end of the pistol **CAN** cause the bolt stop to disengage and to feed a cartridge into the chamber. The bolt stop should only be relied upon to hold the bolt in its rearward position when the chamber is empty and an empty magazine is in place. The bolt stop is there for convenience when changing magazines and to hold the bolt in its rearward position when the pistol is unloaded for cleaning or inspection.

NOTE: The **RUGER® PC CHARGER™** also has an automatic last round hold open. Once the last round of a magazine is extracted and ejected, the follower of the magazine engages the last round hold open. The last round hold open will hold the bolt in an open position after the last round is fired.

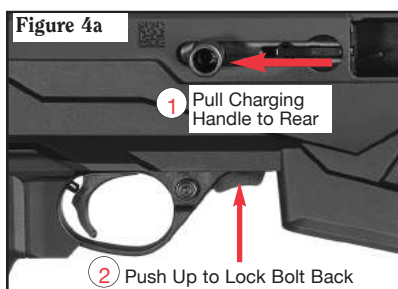

To release the bolt: Once the empty magazine has been removed, or replaced with a loaded magazine, retract the charging handle to its extreme rearward position and release it. This will cause the bolt stop to drop and the bolt to be released and move forward. (See Figure 4b.)

When the last shot has been fired and the magazine is empty, the last round hold open automatically holds the bolt open. If a loaded magazine is inserted in the pistol when the bolt is closed and the bolt is then retracted fully, the last round hold open will not automatically hold open the bolt. The user can actuate the bolt stop mechanism to hold the bolt open at any time by retracting the bolt with the charging handle and pushing up the bolt stop.

MAGAZINE WELL REMOVAL & REPLACEMENT

Make Sure Firearm Is Unloaded!

The magazine well of the **RUGER® PC CHARGER™** is interchangeable to accommodate alternative magazines. The **RUGER® PC CHARGER™** is shipped with a magazine compatible with the installed magazine well assembly marked either “SR9 S9” or “R9 R40.” A magazine well assembly marked either “G9” or “G9 G40,” that is compatible with Glock®-style magazines, is included in the shipping box. **RUGER AMERICAN PISTOL®** magazine well assemblies are available at ShopRuger.com.

NOTE: Although some SECURITY-9® magazines may fit and appear to properly latch into SR-SERIES™ pistols chambered in 9mm Luger, customers may experience higher than normal magazine-related failures if used in these pistols. Therefore, Ruger does not recommend using SECURITY-9® magazines in SR-SERIES™ pistols. Security-9® and SR-SERIES™ magazines appear similar but can easily be distinguished from each other by the location of manufacture marked on the magazine body. SECURITY-9® magazine bodies are marked as “MADE IN USA” while SR-SERIES™ magazine bodies are marked as “MADE IN ITALY.”

NOTE: Older Glock® magazines that feature only one magazine latch slot may still be used with the **PC CHARGER™**, but the magazine release button must remain on the left side of the pistol as shipped from the factory. The magazine release button should not be reversed when using this type of magazine as the magazine will not properly lock into the magazine well. Early versions of Glock®-brand magazines with a “U” shaped notch at the rear of the magazine feed lips will not function in the **PC CHARGER™**.

To remove the magazine well:

1. With the firearm pointing in a safe direction, remove the magazine and lock the bolt back (see Figure 4a, p. 14). Visually make certain there is not a cartridge in the chamber. Place the safety in the “ON” position (see Figure 1C, p. 8).
2. To remove the barrel/handguard assembly, with the bolt still in the locked back position, push the locking lever forward to unlock the barrel/handguard assembly. (See Figure 5.)
3. While holding the locking lever forward, rotate the barrel/handguard assembly **counterclockwise** and pull the barrel/handguard assembly out of the receiver. (See Figure 5.)

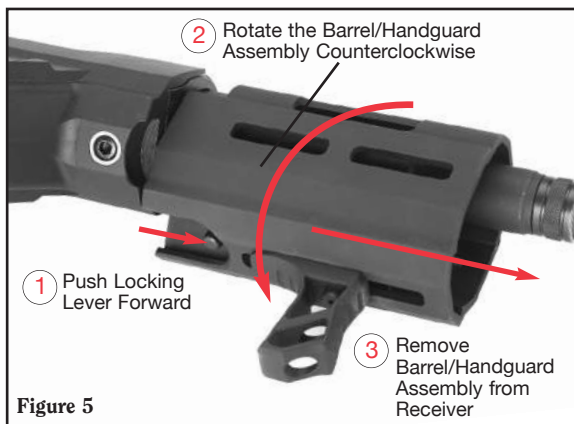

- Retract the charging handle fully rearward and slowly release it until the bolt comes to rest in its forward position.
- Use a 5/32" hex wrench to loosen (do not remove) the forward takedown screw from the chassis. (See Figure 6.)

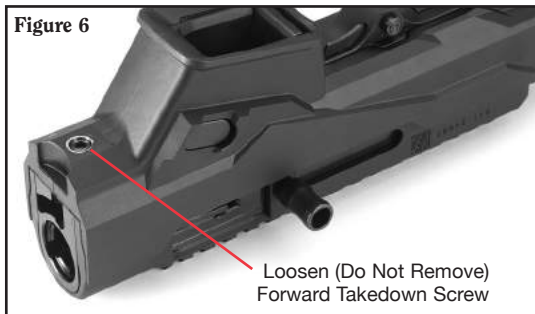

- Use a 5/32" hex wrench to remove the grip mount retaining screw. Removal of the grip mount retaining screw allows the grip mount and grip to be separated from the chassis. (See Figure 7.)



- Lift the receiver assembly upward and away from the chassis. (See Figure 8.)

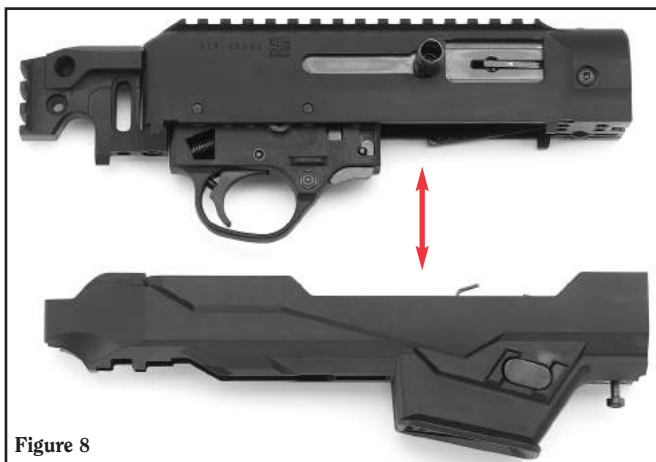

8. In order to remove the magazine well assembly, the magazine release button and magazine latch must both be compressed (see Figure 9a) while removing the magazine well upward and out of the chassis (see Figure 9b). **NOTE:** The Glock®-style magazine well insert does not require magazine latch compression.

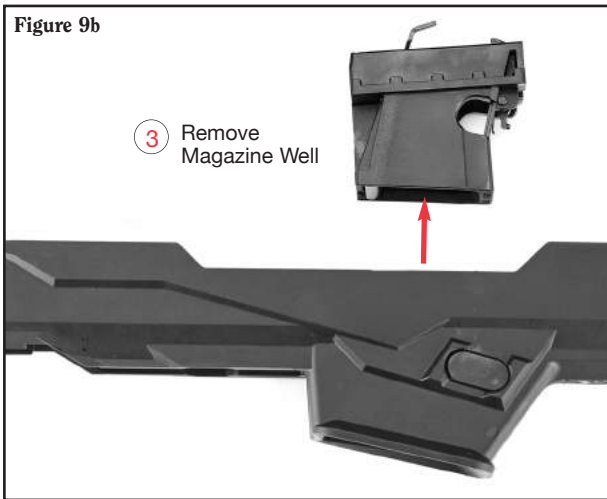
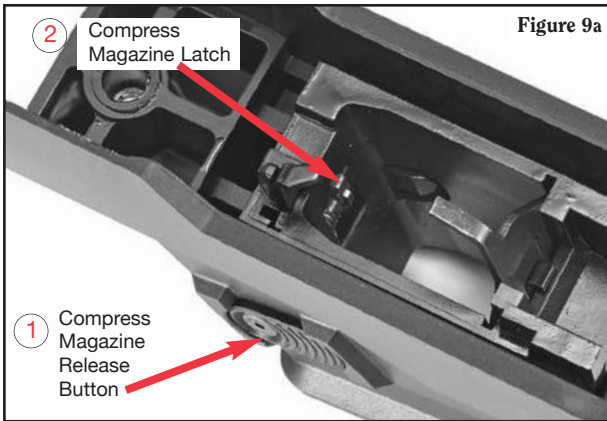

To insert the magazine well:

1. Compress the magazine latch and magazine release button while inserting the magazine well into the chassis (refer to Figures 9a and 9b, p. 17).
2. Place the receiver into the chassis (see Figure 10).

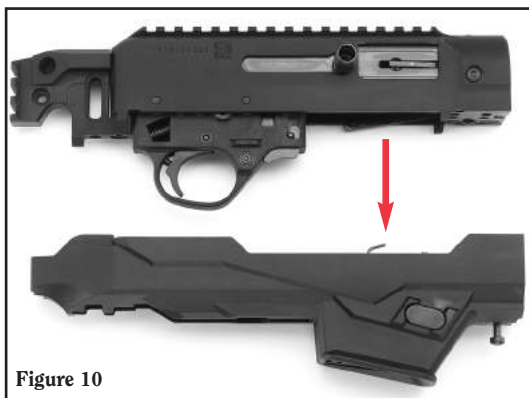

3. Secure the front takedown screw to 65 inch-pounds with a 5/32" hex wrench. (See Figure 11.)

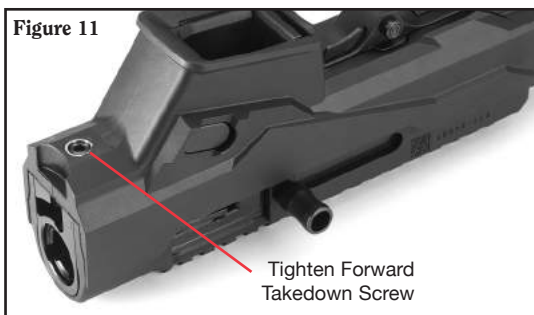

4. Align the pistol grip mount onto the chassis and secure the grip mount retaining screw to 65 inch-pounds with a 5/32" hex wrench. Securing the grip mount retaining screw sandwiches the chassis between the grip mount and receiver brace. (See Figure 12.)

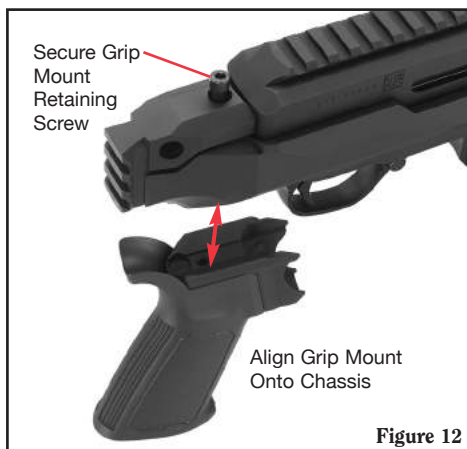

5. Place the bolt in the rearward position and manually engage the bolt stop.
6. Install the barrel/handguard assembly by inserting it into the receiver as shown in Figure 13, and rotating it **clockwise** until it locks into place.

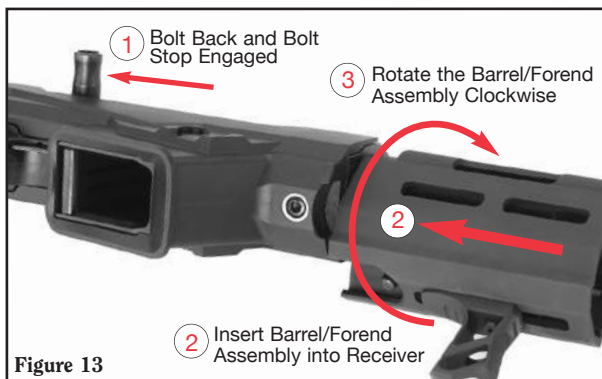

REVERSIBLE MAGAZINE RELEASE

Make Sure Firearm Is Unloaded!

The magazine release of the **RUGER® PC CHARGER™** can be configured for either left- or right-handed operation.

NOTE: See important information regarding older Glock® magazines on p. 15.

1. In order to remove the magazine release, the barrel/handguard assembly must be removed (see p. 15, step 2 and Figure 5) from the action and the bolt must be placed in the forward position. (See Figure 14.)



2. Use a 5/32" hex wrench to loosen (but do not remove) the forward takedown screw from the chassis. Use a 5/32" hex wrench to remove the grip mount retention screw. Removal of the grip mount retention screw allows the grip mount and grip to be separated from the chassis. The action must then be removed from the chassis, as well as the magazine well assembly. (See Figure 15.)

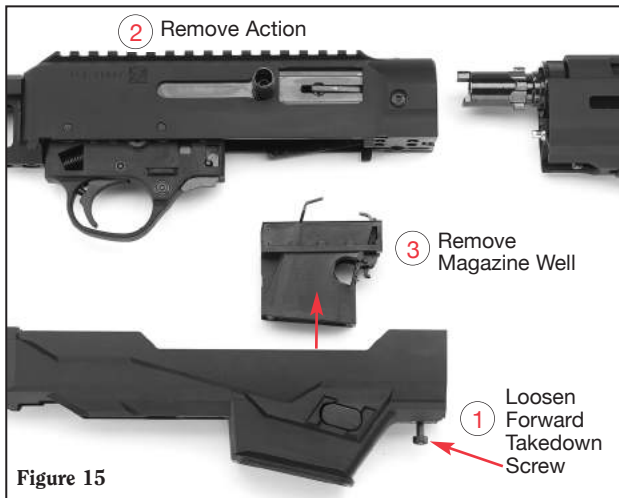

Removal of the magazine well assembly is further detailed in the “Magazine Well Removal and Replacement” section, p. 15.

3. Using a 5/64" hex wrench, loosen and remove the cap screw retaining the the magazine release button, the magazine release button, the latch stud spring and the magazine release stud. (See Figure 16.)

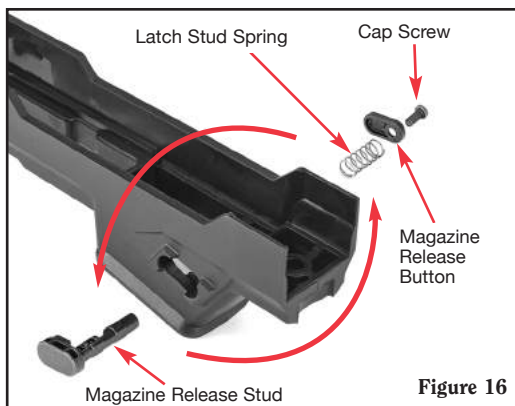

The magazine release stud can then be inserted into the opposite side of the chassis. The latch stud spring is then inserted into the opposing end of the magazine release stud. The magazine release button compresses the latch stud spring and is retained by the cap head screw, torqued to 15 inch-pounds.

REVERSIBLE CHARGING HANDLE

Make Sure Firearm Is Unloaded!

The charging handle of the **RUGER® PC CHARGER™** can be configured for either left- or right-handed operation.

1. In order to remove the charging handle, the barrel/handguard assembly must be attached to the action and the bolt must be in the forward position. (See Figure 17.)



Figure 17. Location of Charging Handle for Disassembly

2. A 5/32" hex wrench must then be used to loosen the cap screw within the charging handle (see Figure 18). Once loosened and removed, the charging handle assembly (comprised of the charging handle and cap screw) can be installed on the opposite side of the pistol.

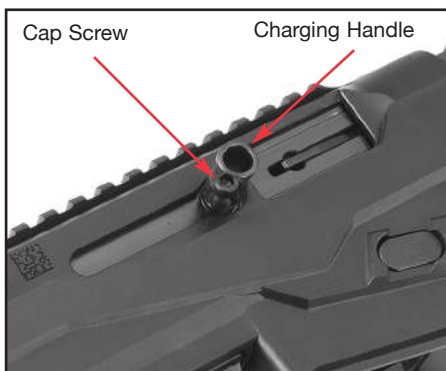

Figure 18.
Loosen & Remove Charging Handle Screw

3. With the bolt closed, align the conical base of the charging handle with the corresponding countersink on the bolt by passing through the charging handle slot of the receiver (see Figure 19). Tighten the cap screw to 65 inch-pounds to ensure the handle is secure. The charging handle torque should be verified every 1,000 rounds or whenever the charging handle is removed and reinstalled.

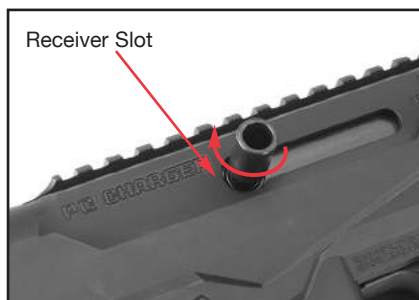

Figure 19.
Insert & Tighten Charging Handle Screw

OPERATION OF SAFETY

The **RUGER® PC CHARGER™** has a cross-button safety which is located in the forward portion of the trigger guard (See Figure 1C, p. 8.) The safety can be operated only when the hammer is cocked.

The safety is “ON” when it protrudes fully from the right side (the ejection side) of the trigger guard assembly, as shown in Figure 1C, p. 8. In this position the sear is blocked, and the firearm cannot be fired from a normal pull on the trigger.

The safety should always be in the “ON” (safe) position except when the shooter is actually firing the firearm. The safety should be moved to the “ON” position whenever the shooter ceases firing, even temporarily.

The safety is in the “OFF” (fire) position when it protrudes from the left side of the trigger guard assembly, as shown in Figure 20. When the safety is off, the red band shows on the safety button. Do not totally rely on the appearance of the red band to indicate that the safety is off. In poor light or if dirt is present, the red band may not be visible. **If the safety is “OFF” and the trigger is pulled, the pistol will fire.**

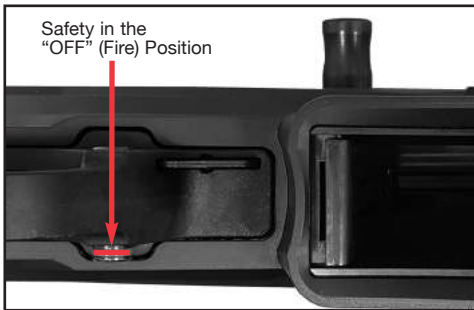
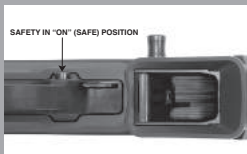

Figure 20. The underside of the trigger guard section of the pistol. In this illustration, the safety is shown in the “OFF” (fire) position. The position of the safety and red band indicate the safety is “OFF.” **If the pistol is loaded, the safety should be “OFF” only when you are actually firing at a target.**

The safety is held in its “ON” or “OFF” position by a plunger that is under spring compression. When the safety is moved to either the “ON” or “OFF” position, a distinct “click” should be heard. Frequently check the position of the safety to be certain the safety has not been inadvertently moved. If the safety seems to move too easily, or if the “click” is not heard when the safety is moved, stop using the pistol and return it to the Newport Customer Service Department for repair (see p. 45).



WARNING – MANUAL SAFETY



Keep the safety “ON” unless actually firing. Always move the safety fully to its intended position and check it. The safety is not “ON” unless it is completely “ON.” Never depend on a safety mechanism or any other mechanical device to justify careless handling or permitting the pistol to point in an unsafe direction. The only “safe” pistol is one in which the bolt is open, the chamber is empty, and there is no magazine in the firearm.

KNOW HOW TO USE THE SAFETY

AMMUNITION



The **RUGER® PC CHARGER™** is chambered for, and designed to properly function with, only factory loaded 9mm Luger (Parabellum) standard, high velocity, or +P ammunition, manufactured to U.S. industry standards.

Use only such factory ammunition in good condition that exactly matches the caliber of your pistol that is marked on the barrel.

		WARNING – AMMUNITION
		<p>Use only new, factory ammunition of the correct caliber. Death, serious injury, and damage can result from the wrong ammunition, bore obstructions, powder overloads or incorrect cartridge components. <u>Always</u> wear shooting glasses and hearing protection.</p>
		
		IMPROPER AMMUNITION DESTROYS FIREARMS

AMMUNITION (CARTRIDGES) NOTICE

WE SPECIFICALLY DISCLAIM RESPONSIBILITY FOR ANY DAMAGE OR INJURY WHATSOEVER OCCURRING IN CONNECTION WITH, OR AS A RESULT OF, THE USE IN ANY RUGER FIREARMS OF FAULTY, OR NON-STANDARD, OR “REMANUFACTURED” OR HAND-LOADED (RELOADED) AMMUNITION, OR OF CARTRIDGES OTHER THAN THOSE FOR WHICH THE FIREARM WAS ORIGINALLY CHAMBERED.

		WARNING – LEAD EXPOSURE
		<p>Discharging firearms in poorly ventilated areas, cleaning firearms, or handling ammunition may result in exposure to lead and other substances known to the State of California to cause birth defects, reproductive harm, and other serious physical injury. Have adequate ventilation at all times. Wash hands thoroughly after exposure.</p>

MAGAZINES

Depending on the magazine well installed, the **PC CHARGER™** will accept **RUGER® SECURITY-9®**, **RUGER®SR9®** and Glock®-style 9mm magazines. It will also accept 9mm **RUGER AMERICAN PISTOL®** magazines using the separately available **RUGER AMERICAN PISTOL®** magazine well, which is offered for sale at ShopRuger.com.

NOTE: Be sure the appropriate magazine well is installed in your firearm. Refer to the “Magazine Well Removal & Replacement” instructions on p. 15. Use only high-quality magazines which are clean and in good working order. Ruger® magazines that have been tested and approved for use with the **PC CHARGER™** are available through Ruger® Accessories sales Monday through Friday, 7:30 a.m. - 6:00 p.m. at 1-336-949-5200 ET or 24 hours a day, 7 days a week on the web at ShopRuger.com.

LOADING THE MAGAZINE

Use only clean, dry ammunition of the proper caliber manufactured to U. S. Industry specifications, in good condition. (See Notice and Warnings in other sections of this manual pertaining to Ammunition).

To load the magazine, align a cartridge with the bullet forward and slide under the feed lips until the cartridge snaps into place. Repeat this process until the desired number of cartridges are loaded. Do not attempt to load more than the designated number of cartridges for which the magazine has been designed.

**DAMAGED, NON-STANDARD OR IMPROPERLY ASSEMBLED
MAGAZINES SHOULD NOT BE USED. THEY CAN CAUSE THE
FIREARM TO MALFUNCTION.**

TO LOAD AND FIRE (WITH MAGAZINE)



Practice this important aspect of firearm handling (with an unloaded firearm) until you can perform each of the steps – described below – with skill and confidence. But before you do anything with the pistol, please first read completely through this manual. **Keep your finger off the trigger until you are ready to immediately shoot at a target!**

1. **Keep the muzzle pointed in a safe direction.** (See Rule 2, p. 54).
2. **If the hammer is cocked, put the safety “ON”** (fully protruding from the right side of the trigger guard). (See Figure 1C, p. 8.)
3. Pull the charging handle rearward. Engage the bolt stop so that the bolt is held open. **Check the chamber to be certain it is empty.** Engage the safety if not already done.
4. To remove the magazine, use your thumb to depress the magazine release button on the left or right side of the magazine well and at the same time grasp the magazine between your fingers and palm of the same hand to draw it out of the magazine well. (See Figure 21, p. 25). Do not drop the magazine out of the pistol onto a hard or dirty surface -- you may damage it or otherwise induce malfunctions.

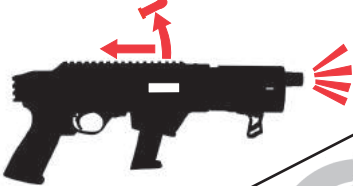

Figure 21. If the hammer is cocked, the safety should be “ON” when the magazine is being removed or inserted. When the magazine release button is pushed in, the magazine is released. Depress the button with your thumb and at the same time grasp the magazine and draw it downward out of the firearm. **REMEMBER** to check to be sure the chamber is empty after removing the magazine!

5. Load a magazine with the desired number of cartridges.
6. Insert magazine fully into the firearm (with bullet end of the cartridges toward the muzzle) until it is locked in place by the magazine latch. (Magazine cannot be seated if inserted incorrectly).
7. Load a cartridge into the chamber by fully retracting the charging handle and releasing it. The bolt will forcibly move forward, chambering a cartridge from the magazine. **Don't touch the trigger.** Do not 'ride' the charging handle as it moves forward. Do not apply force to the charging handle to chamber a cartridge. If a cartridge does not readily chamber, eject it from the firearm, hold the bolt open with the bolt stop, remove the magazine and see MALFUNCTIONS WARNING, p. 31.
8. The firearm is now fully loaded. **If the firearm is not to be fired immediately, the safety should remain “ON”** (see Figure 1C, p. 8). When the safety is moved to the “OFF” position, the firearm will fire a cartridge each time the trigger is pulled until all the cartridges in the magazine, and the one in the chamber, have been fired. Firing will automatically reload and recock the firearm. **Note that every time the trigger is pulled, if a cartridge is in the chamber and the safety is “OFF,” the firearm will fire – be careful!**

 <h2 style="margin: 0;">WARNING – FIRING</h2>	
	<p>The bolt automatically opens and shuts quickly while firing. Keep face and hands away from it. Hot brass and powder gas are ejected quickly and can burn you. Always wear shooting glasses and hearing protection.</p>
	<p>BOLT OPENS FAST– HOT BRASS EJECTED</p>

9. Immediately following the firing of a shot, if a subsequent shot is not to be fired at once, put the safety "ON" while the firearm is still pointing in a safe direction down range. The safety should be moved to the "ON" position as soon as firing is completed, and it should be "ON" at all times except when the firearm is on target and being fired.
10. If all cartridges are fired from the magazine, the bolt remains open after the last shot has been fired. When firing is completed, if the bolt is shut, manually retract the bolt, hold it open by pushing the bolt stop up, and visually check the chamber to be sure it is empty. **If the bolt is shut, you should always assume that there is a cartridge in the chamber. Don't rely on your memory to know if a firearm or magazine is loaded. Visually inspect the magazine and the chamber.**



 WARNING – HANDLING	
 <p>SAFETY IN OFF POSITION</p>	<p>If dropped or struck with the safety "off", the firearm may fire. Keep chamber empty unless actually firing! Keep safety "ON" unless actually firing!</p> <p>ANY FIREARM MAY FIRE IF DROPPED</p>

TO LOAD AND FIRE (WITHOUT MAGAZINE)

The **PC CHARGER™** can be used in a single-shot mode in the absence of a magazine or for safety or training purposes. To do so, follow steps 1 through 3, on p. 24. Next, carefully place a single cartridge into the chamber. The chamber can be accessed through the ejection port. Retract the charging handle to its extreme rearward position and release it. This will cause the bolt to be released and move fully forward. The firearm is now loaded.

CAUTION: The bolt is under heavy spring tension and can injure fingers if it were to slam shut!

If the firearm is not to be fired immediately, the safety should remain “ON.” Firing the firearm will cock the hammer though, without a magazine, the bolt will not remain open after the single round is fired.

 WARNING – UNLOADING	
	So that the firearm can be used as a single loader, it will fire whether or not a magazine is in the firearm if a cartridge is chambered. Removing the magazine does not unload the firearm! To unload, first remove magazine, then pull bolt to the rear, eject chambered cartridge, and visually inspect chamber. If the hammer is cocked, the safety should always be in the “ON” (safe) position when loading or unloading the pistol.
FIREARM WILL FIRE WITH MAGAZINE OUT	

TO UNLOAD

(Firearm Must Be Kept Pointed In A Safe Direction)

UNLOAD THE FIREARM IMMEDIATELY WHEN YOU ARE FINISHED SHOOTING!

NOTE: This sequence must be followed exactly. Failure to do so can result in the firearm’s chamber becoming unintentionally loaded with a cartridge!

1. Keep the muzzle pointed in a safe direction at all times and keep fingers outside the trigger guard. If the hammer is cocked, **move the safety to the “ON” position.**
2. Remove the magazine. **Remember that even though the magazine has been removed, a cartridge remaining in the chamber can still be fired!**
3. Retract the bolt to its open position and hold it in place by pressing the bolt stop up (see p. 14).
4. **Always visually double check the chamber to be certain it is empty.** Engage the safety if not already done.
5. The only “safe” firearm is one in which the bolt is open, the chamber is empty, and there is no magazine in the firearm.

CORRECT UNLOADING SEQUENCE

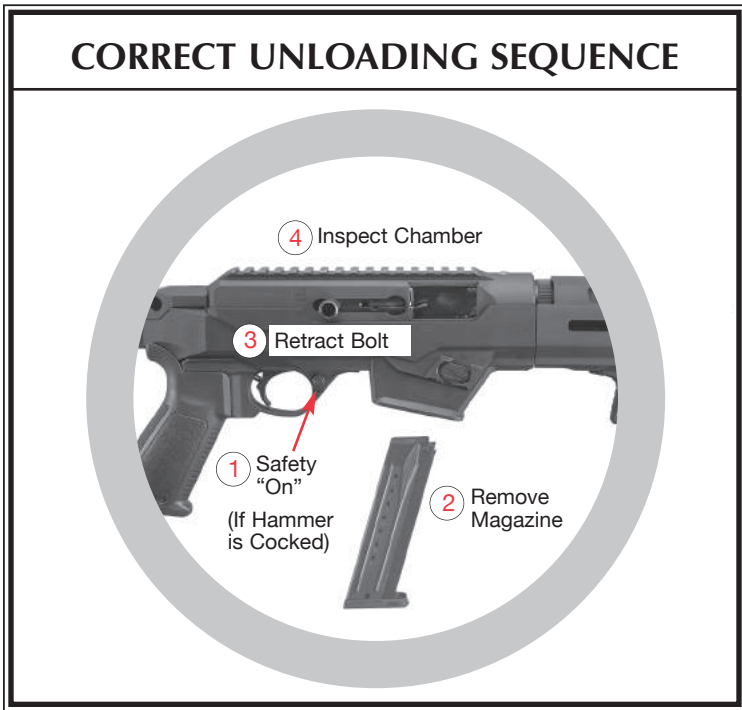

6. Cartridges can be removed from the magazine by sliding each cartridge forward and out of the magazine, one at a time, until the magazine is empty. **Do not use a loaded cartridge or other items as a 'tool' to strip cartridges from the magazine.**
7. If desired, the bolt can be left in the open position, being held there by the bolt stop. **If it is desired to close the bolt, again look to be certain the chamber is empty and there is no magazine in the pistol.** Retract the bolt to its rearmost position, release and let the bolt snap forward. **Keep your fingers out of the receiver!**
8. **With the muzzle pointed in a safe direction,** push the safety to the "OFF" position and pull the trigger to decock it. The pistol can be "dry fired" for practice **as long as it is empty and pointed in a safe direction.**
9. Push empty (unloaded) magazine into the pistol until the magazine latch locks it in place. If an empty magazine is inserted into a pistol with the bolt held open, the bolt will not close due to the last round hold open.

TO EXTRACT AND EJECT A CHAMBERED CARTRIDGE

When the firearm is fired, the same gas pressure which drives the bullet forward also acts through the cartridge case to push the bolt to the rear. That action causes extraction and ejection of the fired cartridge case. But, when the bolt is operated by hand, there can be a failure to extract the cartridge from the chamber, or a failure to eject the cartridge clear of the firearm. These failures usually are the result of the bolt not being pulled rearward vigorously, coupled with an accumulation of firing residue in the chamber. From the foregoing, it is clear that the firearm user must:

1. **Always visually check the chamber after opening the bolt to eject a chambered cartridge.** If the bolt is not vigorously retracted when being operated by hand, the extracted cartridge can be 'ejected' into the magazine area, instead of outside the firearm. (Remember that the magazine should be removed prior to unloading the chamber.)
2. Thoroughly clean the chamber and the extractor as often as necessary to prevent the accumulation of grease and dirt.
3. If an empty magazine is in the firearm when the bolt is being hand retracted to extract a cartridge, the cartridge may drop on top of the magazine. **Always remove the magazine before clearing the chamber, and visually ensure that no cartridges remain in the firearm.**

TO CLEAR A MALFUNCTION ("JAM" or "MISFIRE")

Any autoloading firearm may occasionally malfunction. If it does:

1. **Be certain the muzzle is pointed in a safe direction and the safety is "ON" if the hammer is cocked.**
2. If the misfire is the result of a cartridge not firing or unusual report (either louder or quieter than normal), keep the pistol pointed in a safe direction for 30 seconds prior to ejecting the chambered round or retracting the bolt.
3. If possible, first remove the magazine. It may be necessary to manually remove a jammed cartridge which has only partially been stripped from the magazine. If so, use extreme care. Hold the bolt open with the bolt stop before attempting to clear the jam. Drawing the bolt fully to the rear may bring the jammed cartridge along. **Keep your face away from the ejection port during this operation.** When attempting to clear a jam, use only wood 'tools' so that a cartridge will not be ignited if you strike a primer, and so that the chamber and magazine will not be damaged. A 3/16" wood dowel rod with a point on one end is useful.
4. Visually check to make sure all cartridges have been removed from the firearm. Safely dispose of any cartridges involved in a malfunction incident. Do not use damaged ammunition in any firearm.

TO MINIMIZE MALFUNCTIONS ("JAMS" or "MISFIRES")

Most malfunctions are caused by improper or damaged magazines, incorrect ammunition, or poor maintenance.

1. If it appears that the firearm and magazine are not at fault and that the jam was caused by the type of cartridge being used, then try another type.
2. If changing to another type or brand of cartridges does not at once eliminate malfunctioning, then the following steps should be taken:
 - a. **Make certain the firearm and the magazine are unloaded and that the safety is "ON." Remember, the magazine should be removed first, then check the chamber and be certain it and the magazine well are clear of cartridges.**
 - b. Thoroughly clean the magazine and bolt mechanism (see p. 33 for detailed instructions on how to disassemble the bolt for cleaning), paying particular attention to removing accumulated grease. Use a bristle brush and solvent to remove grease and fouling from the bolt, the extractor, the chamber, and the feed ramp. (See the "Care and Cleaning" section of this manual for detailed cleaning instructions).
 - c. Check to see that the magazine spring tension is adequate and that the magazine follower moves freely up and down.
 - d. Check the magazine lips to be certain they are free of nicks and burrs and are not deformed.
 - e. Remove excess oil and solvent from all cleaned components, load the magazine, and try the firearm again. As always, proceed slowly. **Be certain bystanders are not close and that you are wearing eye and hearing protection and that your face is a safe distance from the firearm so that any discharge resulting from a jammed cartridge will not injure anyone.**

If the above procedures do not result in a smooth and reliably functioning firearm, do not use the firearm. The firearm can be returned directly to our Newport, New Hampshire Customer Service Department for repair. See the Service and Parts Policy section p. 45 of this manual for packing and shipping information.

Another precaution: When using any autoloading firearm, form the habit of examining fired cartridge cases. If they have bulged heads or frequently show splits on any part of the case, the firearm should be returned to the factory for inspection.



WARNING – MALFUNCTIONS



A cartridge fires when the firing pin impacts the primer, and also can be “discharged” before it is chambered if its primer receives a sharp blow. If a cartridge hangs up, jams, or binds when being chambered or when being fed from the magazine into the chamber, **do not attempt to force it into the chamber by pushing or striking the charging handle**. Any jam or feeding problem is a signal to immediately stop using the firearm until it can be determined what is wrong. Most failures of a cartridge to feed or to chamber are caused by a damaged magazine, improper firearm handling, or defective ammunition. **Whatever the cause, cartridge jams can result in the potentially dangerous situation of a cartridge discharging before it is chambered. If this occurs, the cartridge case will rupture and its fragments will fly out of the firearm with sufficient force to cause injury. Always wear shooting glasses and hearing protection! Keep face away from chamber!**

**STRIKING CHARGING HANDLE
CAN BURST CARTRIDGE**



WARNING – DISASSEMBLY



Always unload a firearm before cleaning, lubrication, disassembly, or assembly.

**UNLOAD BEFORE
CLEANING**

DISASSEMBLY

Make Sure Firearm Is Unloaded!

An on-line video demonstrating the disassembly and reassembly of the **RUGER® PC CHARGER™** can be viewed by going to **Ruger.com/TechTips**.

Chassis and Trigger Guard Disassembly:

1. With the firearm pointing in a safe direction, remove the magazine and lock the bolt back (see Figure 4a, p. 14). Visually make certain there is not a cartridge in the chamber. Place the safety in the “ON” position (see Figure 1C, p. 8).
2. To remove the barrel/handguard assembly, with the bolt still in the locked back position, push the locking lever forward to unlock the barrel/handguard assembly (see Figure 22).
3. While holding the locking lever forward, rotate the barrel/handguard assembly **counterclockwise** and pull the barrel/ handguard assembly out of the receiver (see Figure 22).
4. Retract the charging handle fully rearward and slowly release it until the bolt comes to rest in its forward position.

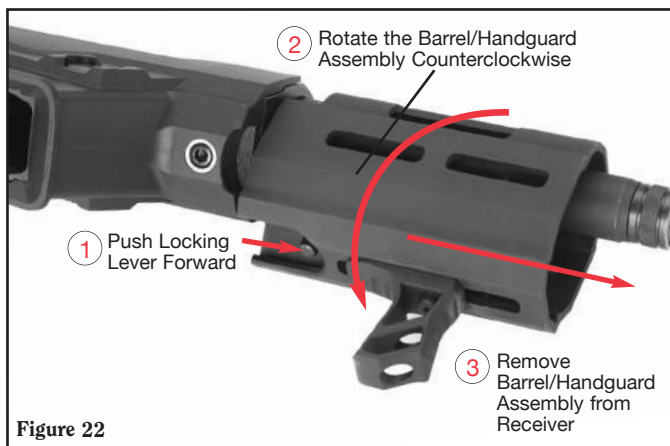

5. Use a 5/32” hex wrench to loosen (do not remove) the forward takedown screw from the chassis. (See Figure 23.)

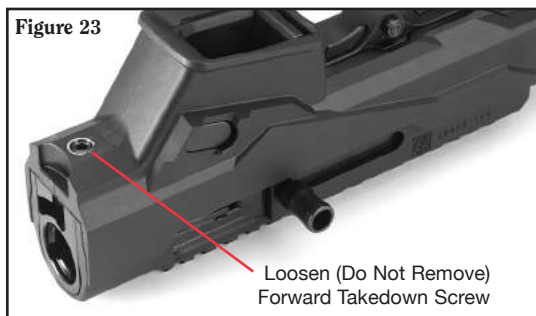

6. Use a 5/32" hex wrench to remove the grip mount retention screw. Removal of the grip mount retention screw allows the grip mount and grip to be separated from the chassis. (See Figure 24.)

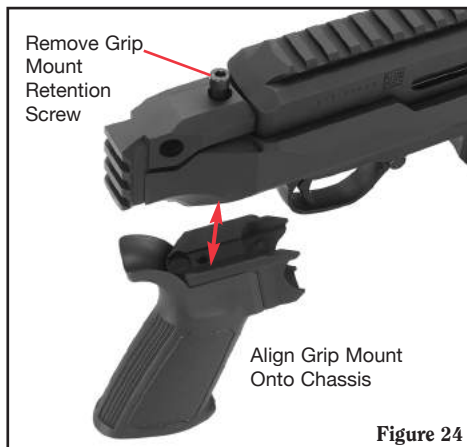

7. Lift the receiver assembly upward and away from the chassis. (See Figure 25.)

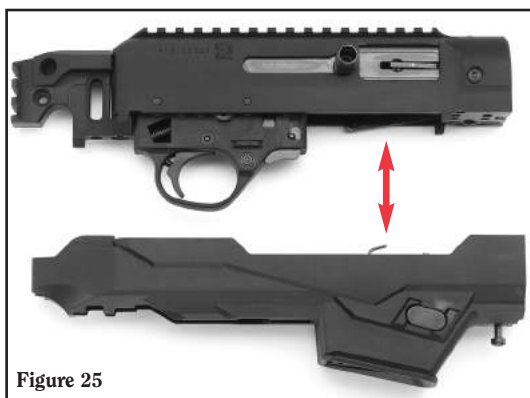

8. Remove the trigger guard by simply drifting out the two trigger guard retaining pins (see Figures 26a & 26b). It is recommended that the components of the trigger guard assembly not be disassembled from the trigger guard.

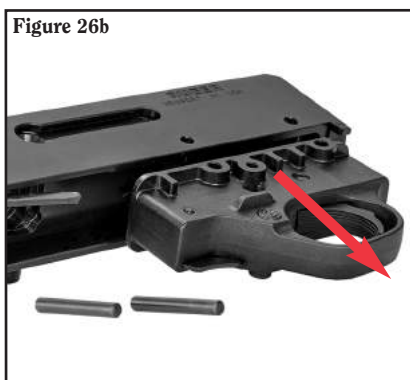
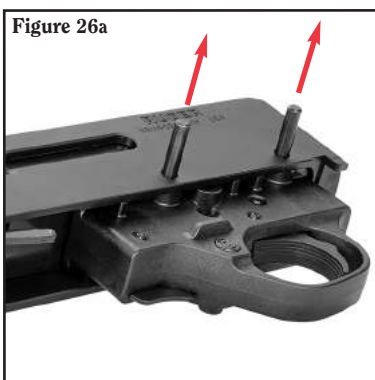

This is the extent of disassembly required for routine inspection, cleaning and lubrication.

If it is desired to thoroughly clean the inside of the receiver by removing the bolt, be aware that although removing and installing the bolt (along with the charging handle-recoil spring assembly) is simple, it must be done correctly.

To remove the bolt – (See Figures 27a & 27b):

1. Position the receiver so the bolt is fully accessible.
2. Use a 5/32" hex wrench to remove the receiver bracket screw. Removal of the receiver bracket from the receiver gives you clearance for bolt removal.
3. Ensure the bolt is in the forward position by pulling back on and carefully releasing the charging handle.
4. Remove the charging handle as described in the “Reversible Charging Handle” section on page 21.
5. Grasping the buffer, lift the bolt assembly out of the receiver (see Figure 27a).

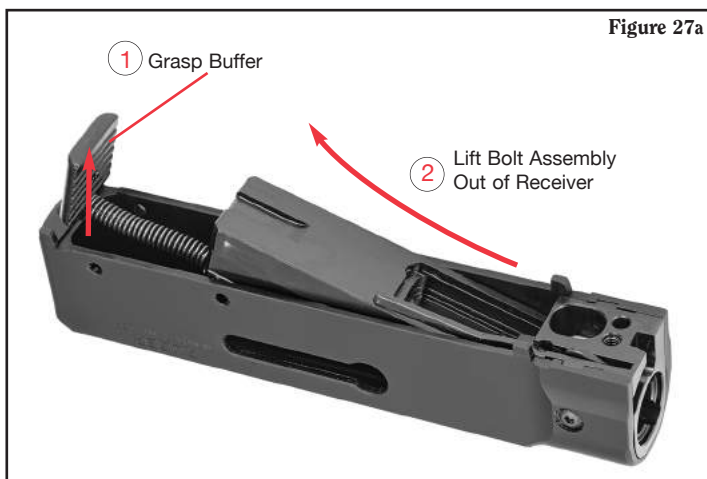

Disassembly of the bolt for cleaning – (See Figures 28 - 31b):

It may occasionally be desirable to clean the bolt and firing pin. Before cleaning, the bolt will need to be disassembled as described below.

1. Slide the bolt top assembly out of the bolt (see Figure 28).

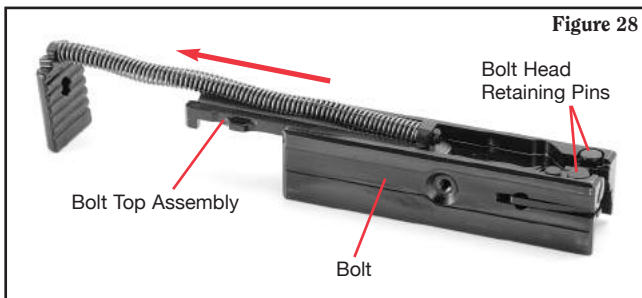

2. Compress the bolt head and flip the bolt over to allow the bolt head retaining pins to drop free (see Figure 29).

The bolt head retaining pins are held in place due to spring load from the firing pin return spring.

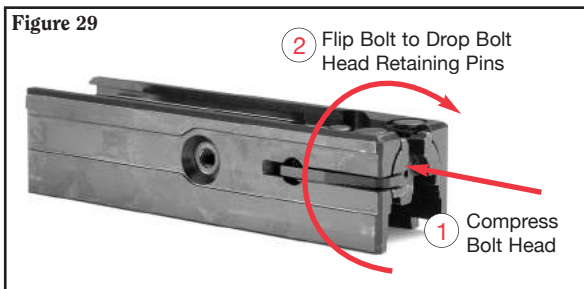

3. Remove the extractor pin using a flat-blade screwdriver (see Figure 30a). Make sure that the extractor is compressed while removing the pin. After the pin is removed, carefully allow the extractor and extractor spring to be removed (see Figure 30b).

CAUTION: The extractor is under spring tension and may “fly” out of the bolt if it is not held in place during removal of the extractor pin.

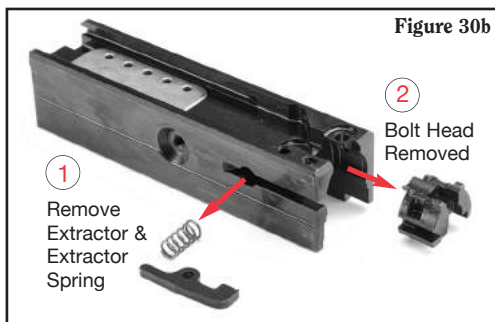
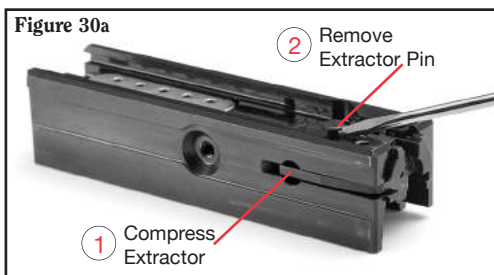

4. Remove the bolt head, the firing pin return spring, and the firing pin (see Figure 31a).
5. Remove the dead blow weight (see Figure 31b).

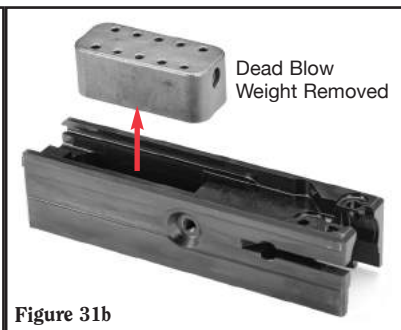
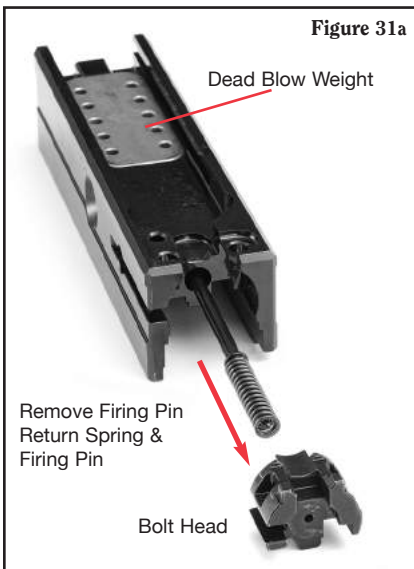

REASSEMBLY

Again, Be Sure Pistol is Unloaded!

Reassembly of the bolt – (See Figures 32 - 36):

1. Insert the dead blow weight into the bolt as oriented in Figures 33b and 34. (see Figure 32).
2. Insert the firing pin, then the firing pin return spring into the bolt (see Figure 33).

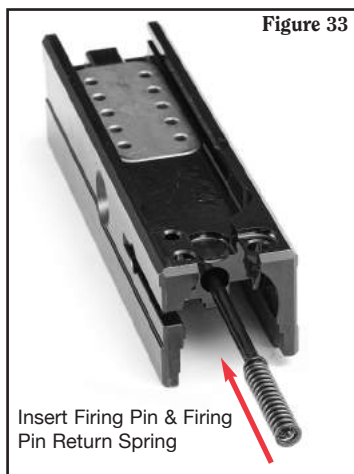
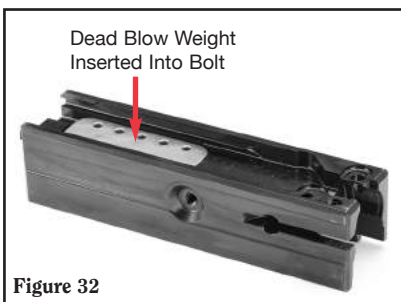

3. Align the bolt head with the bolt, compress the firing pin spring with the bolt head and insert the bolt head retaining pins (see Figure 34).

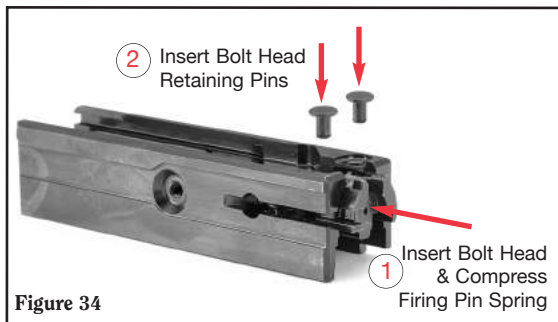

4. Insert the extractor spring and extractor into the extractor hole and slot, respectively. Retain the extractor using the extractor pin (see Figure 35).

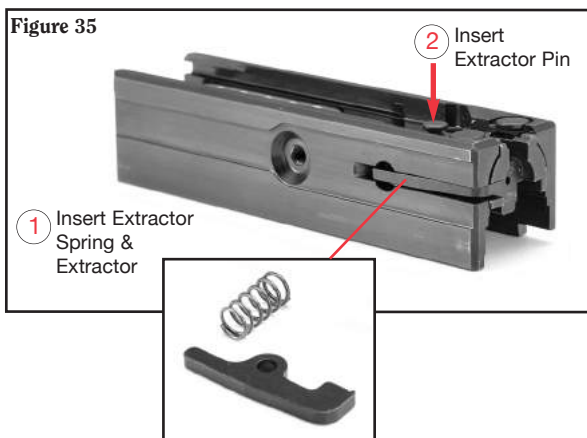

5. Slide the bolt top assembly into the bolt (see Figure 36).

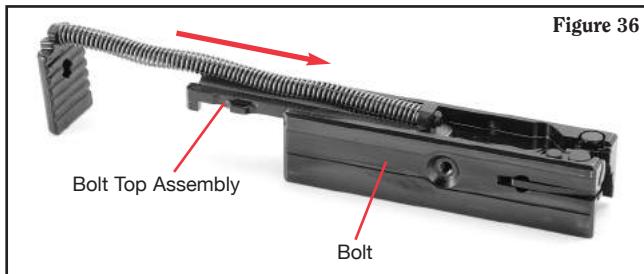

Reassembly of the bolt into the receiver:

1. Grasping the buffer, place the bolt assembly into the receiver with the bolt top facing the top of the receiver. Slide the bolt forward so the bolt head approaches the barrel block and slide the buffer into the back pocket of the receiver. (See Figure 37.) **NOTE:** Do not compress the bolt head against the barrel block until the bolt is fully captured by the receiver. This will prevent the bolt head retaining pins from being inadvertently dislodged.
2. Position the trigger group in alignment with the trigger retaining pin holes and install the trigger retaining pins. (See Figure 38.) The trigger group helps constrain the buffer in the receiver.
3. Reinstall the charging handle onto the bolt. (See “Reversible Charging Handle” section p. 21.)
4. Reinstall the receiver bracket securing it with the receiver bracket screw to 65 inch-pounds with a 5/32” hex wrench. **NOTE:** While tightening the screw, press the rear of the receiver bracket towards the rear of the receiver to ensure the bracket mounts flush to the receiver.

The action is now reassembled and can be installed into the chassis as described below.

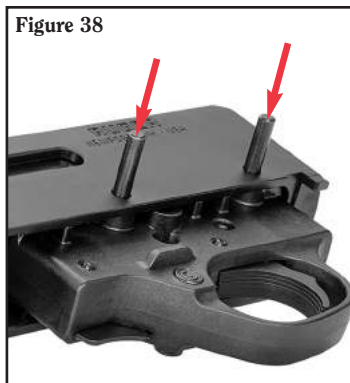
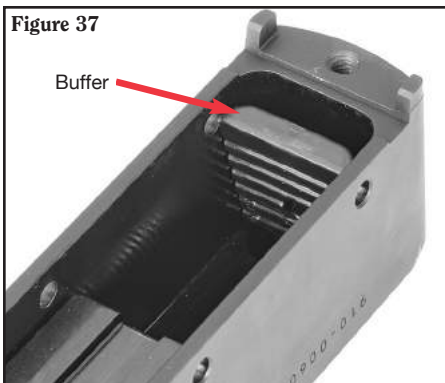

Reassembly of the chassis:

NOTE: Be sure a magazine well has been installed in the chassis before assembling the receiver into the chassis. (See “Magazine Well Removal & Replacement Instructions,” p. 15.)

1. Insert the receiver/trigger guard assembly into the chassis.
(See Figure 39.)

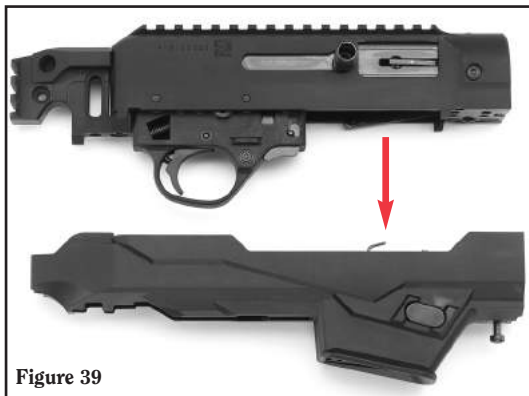

2. Secure the forward takedown screw to 65 inch-pounds with a 5/32" hex wrench.
(See Figure 40.)

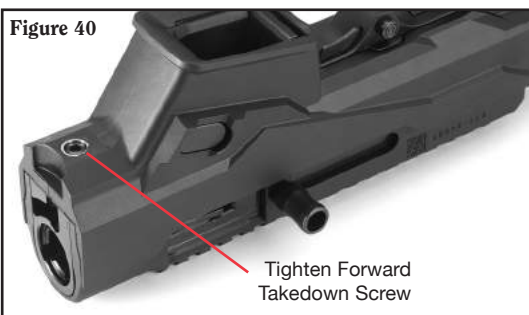

3. Align the pistol grip mount onto the chassis and secure the grip mount retention screw to 65 inch-pounds with a 5/32" hex wrench. Securing the grip mount retaining screw sandwiches the chassis between the grip mount and receiver bracket.
(See Figure 41.)



BARREL/HANDGUARD ASSEMBLY

The **PC CHARGER™** has an adjustable lock-up mechanism. The following directions describe the adjustment necessary to ensure proper lockup the first time the barrel/handguard assembly is installed. After the first adjustment, the barrel/handguard assembly may be installed by following step 2 **only**.

1. Loosen the adjustment knob by turning it **counterclockwise** as far as possible with finger pressure. (See Figure 42.)

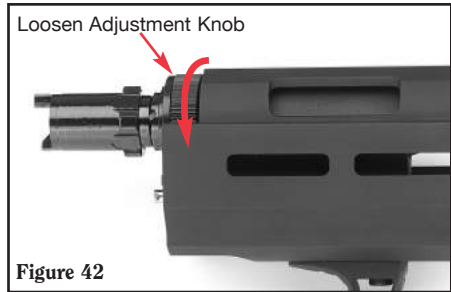

2. Install the barrel/handguard assembly by inserting it into the receiver as shown in Figure 43, and rotating it **clockwise** until it locks into place.

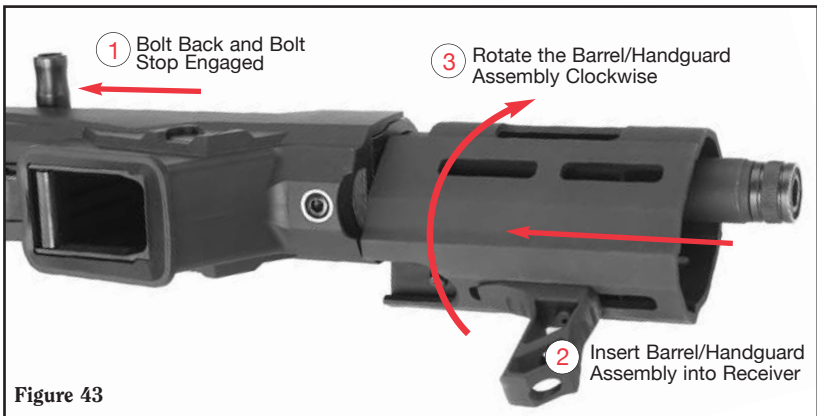

3. Tighten the adjustment knob by rotating it **clockwise** until the barrel/handguard assembly is securely connected.

NOTE: You should feel some resistance when turning the barrel/handguard assembly in the receiver, but it should not be difficult. If further adjustment is needed, remove the barrel/handguard assembly and “tighten” or “loosen” the adjustment knob accordingly.

NOTE: Following barrel installation, the best fired shot accuracy will be achieved if the action is dry cycled prior to actually firing ammunition in the pistol: Remove the magazine from the pistol and be certain the chamber is empty. Keeping the pistol pointed in a safe direction, pull the bolt handle fully to the rear while holding the bolt lock up, then release the bolt handle, letting it “slingshot” (freely fly forward) into the ready-to-fire position. Repeat 2 - 3 times. This will properly “seat” the barrel assembly.

CHECK YOUR PISTOL'S FUNCTION

Periodic inspection of any firearm is important to ensuring its safe operation. It is important to clean and inspect your firearm after each range session or whenever the firearm has been exposed to sand, dust, moisture, humidity, or other adverse conditions. Proper maintenance increases the longevity of your firearm and will allow early detection of worn or broken parts.

Prior to each use, visually inspect the firearm to ensure no components are damaged, missing, loose, bent, cracked, chipped, or peened. If you observe excessive wear, you should stop using your pistol and contact customer service or a trained certified gunsmith to evaluate its condition and replace any worn parts if necessary.

After any disassembly and reassembly, it is important to verify that the action is working correctly before any live firing is attempted.

FIRST, BE SURE THERE IS NO AMMUNITION IN THE CHAMBER OR THE MAGAZINE AND KEEP THE PISTOL POINTED IN A SAFE DIRECTION!

NOTE: The below checks should all be performed without a magazine inserted in the pistol.

a. CHECK THE BOLT FUNCTION: Pull the bolt fully to the rear and release it. The bolt should operate smoothly and travel freely within the receiver without binding. Repeat this process two more times.

b. CHECK THE SAFETY FUNCTION: **NOTE:** When the safety is moved to either the “on” or “off” position, a distinct “click” should be heard. If the safety seems to move too easily, or if the click is not heard when the safety is moved, stop using the pistol and contact Ruger Customer Service at 336-949-5200. For additional information regarding the safety, please refer to the “Operation of Safety” section of this manual.

- First, pull the bolt fully to the rear and release it. This should cock the hammer. Do not dry fire the pistol.
- Next, engage the safety by pushing it into the “on” position and attempt to pull the trigger. With the safety in this position, the trigger should not move and the hammer should not fall.
- Finally, move the safety to the “off” position. With the pistol pointed in a safe direction, pull the trigger and listen for an audible “click” as an indication the hammer has fallen, striking the firing pin.

Repeat this process two more times.

c. CHECK THE BOLT LOCK FUNCTION:

- First, retract the charging handle to its extreme rearward position and, while holding it there, press up on the bolt stop.
- Next, release pressure on the charging handle and it will move forward a fraction of an inch and then be held in its open position by the bolt stop.
- Finally, retract the charging handle to its extreme rearward position and release it. This will cause the bolt stop to drop and the bolt to be released and move forward.

An on-line video demonstrating the disassembly, reassembly, and function check of the **RUGER® PC CHARGER™** can be viewed by going to **Ruger.com/TechTips**.

If any of the above function checks fail or if you are uncertain, please consult a competent gunsmith or contact Ruger Customer Service at 336-949-5200 for further firearm inspection before using the firearm.

MAGAZINE INSPECTION AND CARE

Check the magazine frequently. The magazine follower must move freely and have adequate tension so that each cartridge is quickly raised to the feeding position. The magazine lips should be clean and free of cracks, dents, or nicks, so that cartridges are held in their proper feeding position.

If the magazine becomes dirty, it should be disassembled and thoroughly cleaned. **Be sure the magazine is unloaded before disassembly.** The following disassembly instructions apply:

Snap-On Base - Use a punch to press in on the magazine spring seat where it protrudes into the hole in the magazine floorplate. Slide the magazine floorplate toward the front of the magazine, **be careful to prevent the forcible ejection of the magazine spring seat and compressed magazine spring.** Withdraw the magazine spring seat, magazine spring, and magazine follower from the magazine body. Reassemble in reverse order.

When cleaning is necessary, use a solvent that will not rust the metal components or adversely affect the magazine body. After the magazine has been soaked to loosen foreign matter, be certain to shake it vigorously (with the loading opening away from you) to remove solvent or residue from within the magazine.

Penetrating oils and solvents inside a magazine can “kill” or weaken cartridge primers or powder which can result in failures to fire or other possibly dangerous malfunctions, such as leaving a bullet in the bore!

After cleaning, always check to be certain that the magazine follower movement and tension are correct, and that no solvent or debris remain.

Improper reassembly of the magazine can cause failure to feed, which is a potentially dangerous malfunction. If cleaning does not restore proper tension, or if you experience a problem with the magazine, don't use it. Get a new one.

DAMAGED, NON-STANDARD, OR IMPROPERLY ASSEMBLED MAGAZINES SHOULD NOT BE USED. THEY CAN CAUSE THE PISTOL TO MALFUNCTION.

CARE AND CLEANING

BEFORE CLEANING, BE CERTAIN THE PISTOL AND ITS MAGAZINE ARE UNLOADED.

Cleanliness is most important to the function of this blow-back operated autoloading firearm. Any failures to feed or extract rounds may be indications of a dirty chamber. Use commercially available bore cleaning solution and a brass brush, followed by drying with a cloth patch, to remove any powder residue. **An excess of dirt, powder residue, or oil in the chamber will cause malfunctions and may result in potentially dangerous cartridge case ruptures and release of hot gasses and case fragments when firing.**

At regular intervals, or whenever the firearm has been exposed to sand, dust, extreme humidity, condensation, immersion in water, or other adverse conditions, disassemble, clean and oil it. Proper periodic maintenance is essential to the reliable functioning of any firearm.

The on-line video demonstrating the proper cleaning procedure of the **PC CARBINE™** is the same for the **PC CHARGER™** and can be viewed by going to Ruger.com/TechTips.

To clean the pistol, proceed as follows:

1. Disassemble (field-strip) the firearm to the extent described on page 32.
2. Using a cleaning rod, run a properly sized, solvent-wetted patch through the bore several times. Then attach a solvent-wetted bristle brush to a cleaning rod and run it back and forth the full length of the bore as many times as necessary to remove grease and dirt from the bore and chamber. Clean bore with dry patches and examine. Bore fouling can contribute to reduced accuracy, and grease accumulation in the chamber can interfere with proper feeding of cartridges from the magazine.
3. Using powder solvent on a clean patch or bristle brush, remove powder residue from all components of the mechanism. After cleaning, run a dry patch through the bore, then follow with a patch that is very lightly oiled. Wipe all surfaces clean with cloth, then wipe all surfaces with a patch or cloth that has been very lightly oiled.
4. **NOTE:** Only a light application of oil is needed to provide adequate lubrication of moving parts and to prevent rust. Excess accumulations of oil tend to attract particles of dust and dirt and may congeal in cold weather which can interfere with the safe and reliable functioning of the pistol.
5. **Cleaning the Chassis:** Use of certain cleaning solvents, including those containing acetone, can damage the finish of this part.

 WARNING – LUBRICATION	
	Firing a firearm with oil, grease, or any other material even partially obstructing the bore may result in damage to the firearm and serious injury or death to the shooter and those nearby. Do not spray or apply lubricants directly on ammunition. If the powder of a cartridge is affected by the lubricant, it may not be ignited, but the primer firing may push the bullet into the bore where it may be lodged. Firing a subsequent bullet into the obstructed bore may damage the pistol and cause serious injury or death to the shooter and those nearby. Use lubricants properly. You are responsible for the proper care and maintenance of your firearms.
IMPROPER LUBRICATION DESTROYS FIREARMS	

STORAGE

FIREARMS SHOULD NOT BE STORED LOADED!

**USE THE LOCKING DEVICE SUPPLIED WITH THE FIREARM TO
RENDER IT INOPERATIVE FOR SAFE STORAGE.**

(SEE PAGE 9)

Do not store the firearm in a leather case or scabbard. Leather attracts moisture, even though it may appear to be dry.



WARNING – STORAGE



- Never place or store any firearm in such a manner that it may be dislodged. Firearms should always be stored securely and unloaded, away from children and careless adults.
- Use the locking device supplied with the firearm for storage. The use of a locking device or safety lock is only one aspect of responsible firearms storage.
- For increased safety, firearms should be stored unloaded in a location that is both separate from their ammunition and inaccessible to children and any other unauthorized person.

STORE SECURELY & UNLOADED

SERVICE AND PARTS POLICY

If you have any questions regarding the performance of your **RUGER® PC CHARGER™**, please write or call (336-949-5200) our Customer Service Department in Newport, New Hampshire, fully describing all circumstances and conditions involved. If you should return your firearm to the factory for repair, or order parts for it, please comply with the following suggestions for prompt service:



WARNING: BEFORE SHIPPING ANY FIREARM, BE ABSOLUTELY CERTAIN THAT IT IS UNLOADED. DO NOT SHIP CARTRIDGES WITH A FIREARM.

SHIPPING FIREARMS FOR REPAIR

NOTE: You must obtain a **Repair Authorization Number** before returning your firearm. An authorization number can be obtained by contacting Customer Service online at **Ruger.com** or calling the Customer Service Dept. at 336-949-5200. Firearms should be sent prepaid. We will not accept collect shipments. Any **RUGER® PC CHARGER™** returned to the factory for repair should be sent to: Sturm, Ruger & Company, Inc., Customer Service Department, 411 Sunapee St., Newport, New Hampshire 03773.

The Federal Gun Control Act, as well as the laws of most states and localities, do not prohibit an individual (who is not otherwise barred from purchasing or possessing a firearm) from shipping a firearm directly to the manufacturer for repair. However, before you ship your firearm to us, be certain that your state or locality does not have a law or regulation which will prohibit you from receiving the firearm or any included magazines from us after repair. If such receipt is prohibited, please have a federally licensed firearms dealer ship the firearm to us. If your firearm is sent to us by a dealer, it will be returned to that dealer after being repaired. If a handgun (pistol or revolver) is shipped by an individual who does not hold a Federal Firearms License, it must be shipped for overnight delivery via U.P.S., Federal Express, or other, similar private overnight service.

NOTE: Handguns may not be shipped via U.S. Mail. Persons who do not hold a Federal Firearms License are prohibited by Federal law from shipping a handgun by Mail. Handguns mailed in violation of the law may be impounded or confiscated by the Post Office and the non-FFL may be subject to prosecution.

Please do not include any cases, telescopic sights, or custom accessories with a firearm being shipped to the factory for service. **DO NOT SEND FIREARM BOXES OR LITERATURE THAT YOU CONSIDER TO BE COLLECTOR'S ITEMS – THESE ARE INVARIABLY DAMAGED OR DESTROYED IN SHIPMENT.** Always insure your shipment.

Enclose a letter which includes your name, address, telephone number, firearm serial number and model, and repair authorization number. Describe in detail the trouble you have experienced with your firearm, or the work you wish to have done. Merely stating that the firearm “needs repair” is inadequate information. Please enclose copies of any previous correspondence.

All work performed is subject to a minimum labor charge and charges for shipping and handling. Most models can be reblued, but custom gunsmithing service or nonstandard alterations are NOT AVAILABLE from Ruger Customer Service Departments. Please contact the Customer Service Department for pricing information.

 WARNING – PARTS PURCHASERS	
	<ul style="list-style-type: none">• It is the purchaser's responsibility to be absolutely certain that any parts ordered from the factory are correctly fitted and installed.• Firearms are complicated mechanisms and IMPROPER FITTING OF PARTS MAY RESULT IN A DANGEROUS MALFUNCTION, DAMAGE TO THE FIREARM, AND SERIOUS INJURY TO THE SHOOTER AND OTHER PERSONS.• The purchaser and installer of parts must accept full responsibility for the correct adjustment and functioning of the firearm after such installation.
PARTS MUST FIT CORRECTLY	

ORDERING PARTS

Please contact the Newport, New Hampshire Customer Service Department for parts availability and current prices. All parts ordered for the **RUGER® PC CHARGER™** should be sent to: Sturm, Ruger & Co., Inc., Customer Service Department, 411 Sunapee Street, Newport, New Hampshire 03773, 336-949-5200.

We cannot comply with open account or C.O.D. orders. Payment in full via credit card (Visa or MasterCard only), money order or certified bank check (no personal checks or cash, please) is required before any service will be performed. Please provide your credit card number, your name as it appears on the credit card, the expiration date, and the 3-digit security code. All parts orders are subject to a minimum charge and charges for shipping and handling. Order parts by **Part Name and specify the model and entire serial number** of the firearm for which the parts are being ordered. There is a minimum labor charge plus a shipping and handling charge if the parts are factory fit. All factory fit parts are fit on an exchange basis only. We will not return the replaced parts. Please contact the Customer Service Department for pricing information.

Because the receiver is a serial numbered component, it is defined as a “firearm” by Federal law and is not sold as a separate component.

*Parts designated by an asterisk must be factory fit. These parts are fit on an exchange basis only. We will not return the replaced parts. We will not return any part that is broken, malfunctioning, badly worn or has been modified. See “Warning – Parts Purchasers” above.

	WARNING: A firearm containing broken, malfunctioning, or badly worn parts should not be fired.
---	---

RUGER® PC CHARGER™

PARTS LIST

Design, prices and specifications subject to change without notice.

SPECIFY MODEL, CALIBER AND SERIAL NO. WHEN ORDERING

(See Exploded Views Pages 49 - 53)

Key	Part Name
1	Chassis Assembly – Complete Includes Key Nos. 2 - 6 (See Exploded View p. 49)
2	Latch Stud
3	Magazine Release Spring
4	Latch Button
5	Low Profile Cap Screw
6	Chassis Assembly
7	Magazine Well Assemblies (SR9/G9/American) – Complete Includes Key Nos. 8 - 16 (See Exploded Views p. 51)
8	Ejector
9	Magazine Well, SR9/Security-9
10	Last Round Plunger
11	Latch Pin
12	Magazine Latch, SR9/Security-9
13	Magazine Latch Spring
14	Magazine Well, G9
15	Magazine Well, American 9mm
16	Magazine Latch, American 9mm
† 17	Receiver
* 18	Trigger Assembly – Complete Includes Key Nos. 19 - 37 (See Exploded View p. 52)
* 19	Hammer Strut Washer
* 20	Hammer Strut Spring
* 21	Hammer Strut
* 22	Hammer
* 23	Hammer Pivot Pin
* 24	Trigger Guard
25	Bolt Stop
26	Bolt Stop Spring
* 27	Trigger Pivot Pin
* 28	Trigger Plunger Spring
* 29	Trigger Plunger
* 30	Safety Detent Plunger Spring
* 31	Safety Detent Plunger
* 32	Safety Button
* 33	Trigger
* 34	Sear
* 35	Disconnecter Pin
* 36	Disconnecter
* 37	Disconnecter Spring

* Parts so marked must be factory fit.

† The receiver is a serial-numbered part and is not offered for sale.

Key	Part Name
38	Bolt Assembly – Complete Includes Key Nos. 39 - 52 (See Exploded View p. 52)
39	Bolt
40	Extractor
41	Extractor Spring
42	Extractor Pin
43	Bolt Head
44	Bolt Head Retaining Pins, 2 Req'd
45	Firing Pin
46	Firing Pin Spring
47	Buffer
48	Recoil Spring
49	Recoil Spring Retainer
50	Bolt Top
51	Guide Rod
52	Dead Blow Weight
53	Trigger Guard Cross Pin, 2 Req'd
54	Barrel Block
55	Last Round Catch
56	Last Round Pivot Pin
57	Last Round Spring
58	Button Head Screw, 3 Req'd
59	Charging Handle
60	Cap Screw
61	Barrel/Handguard Assembly – Complete Includes Key Nos. 62 - 74 (See Exploded View p. 53)
62	Barrel
63	Barrel Spacer
64	Adjusting Knob
65	Safety Detent Plunger
66	Locking Plunger Detent
67	Locking Plunger
68	Mounting Screw, 2 Req'd
69	Thread Protector
70	Locking Plunger Spring
71	Detent Spring
72	O-Ring
73	Locking Lever
74	Handguard
75	Receiver Bracket
76	Grip Mount
77	Grip
78	Grip Mount Retention Screw, Long
79	Socket Head Cap Screw, Short
80	Pistol Grip Screw
81	Lock Washer

RUGER® PC CHARGER™

CHASSIS ASSEMBLY

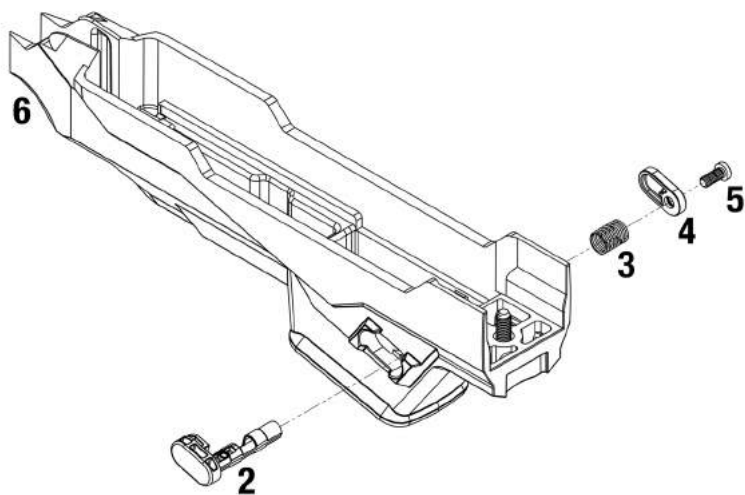

RUGER® PC CHARGER™

EXPLODED VIEW

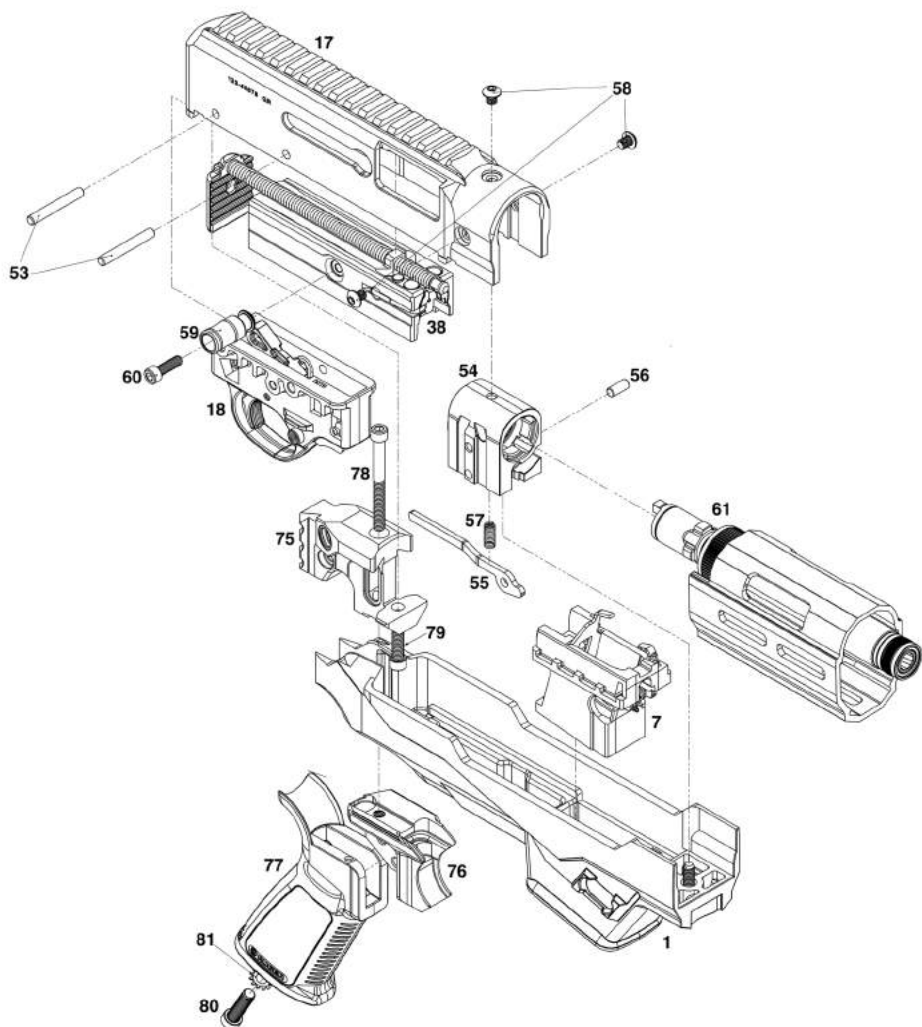

RUGER® PC CHARGER™
MAGAZINE WELL ASSEMBLIES

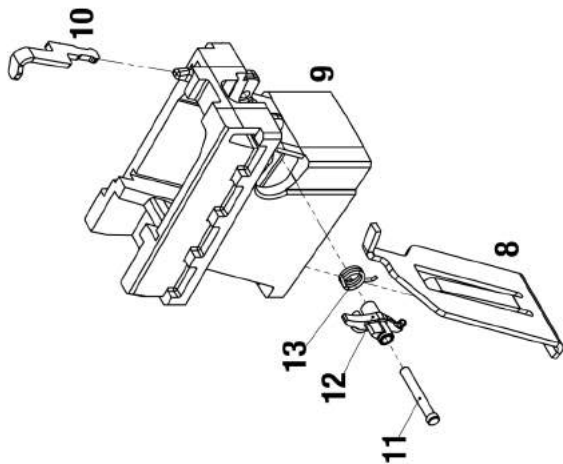

SR9®/SECURITY-9® ASSEMBLY
("SR9 S9" or "R9 R40")

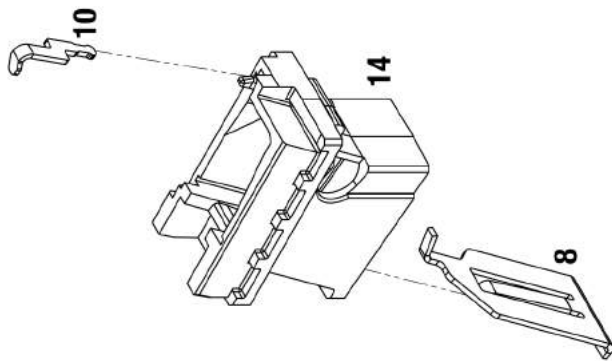

GLOCK®-STYLE ASSEMBLY
("G9" or "G9 G40")

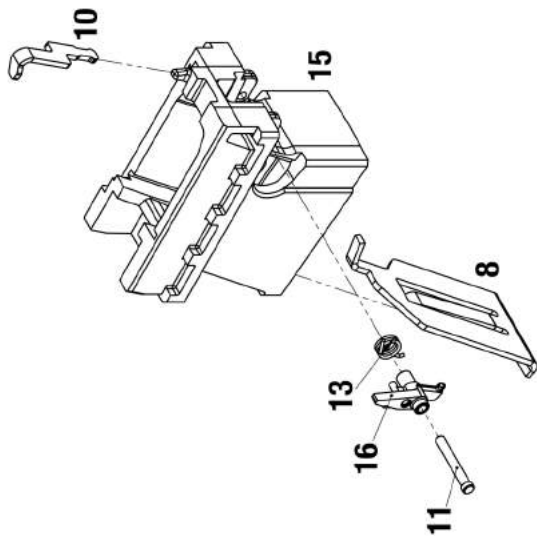

AMERICAN ASSEMBLY
("A9")

RUGER® PC CHARGER™

TRIGGER ASSEMBLY

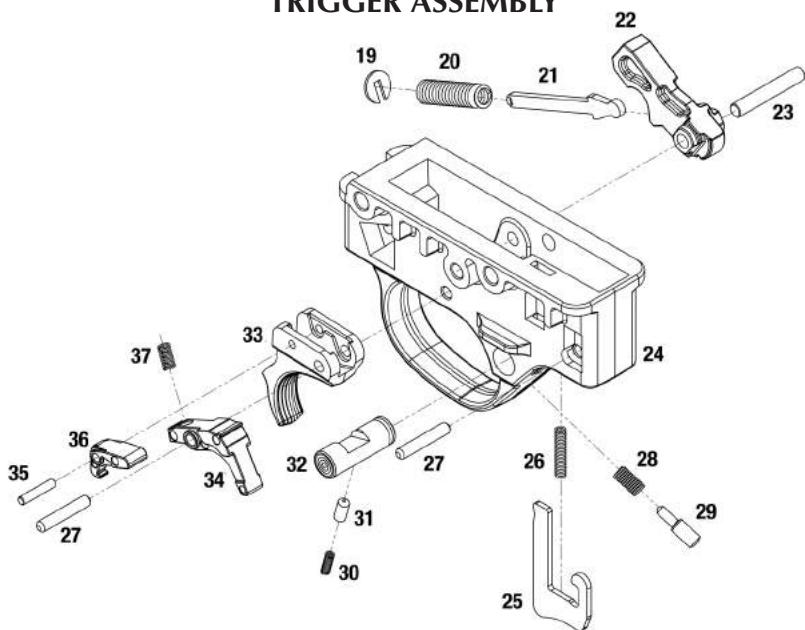

RUGER® PC CHARGER™

BOLT ASSEMBLY

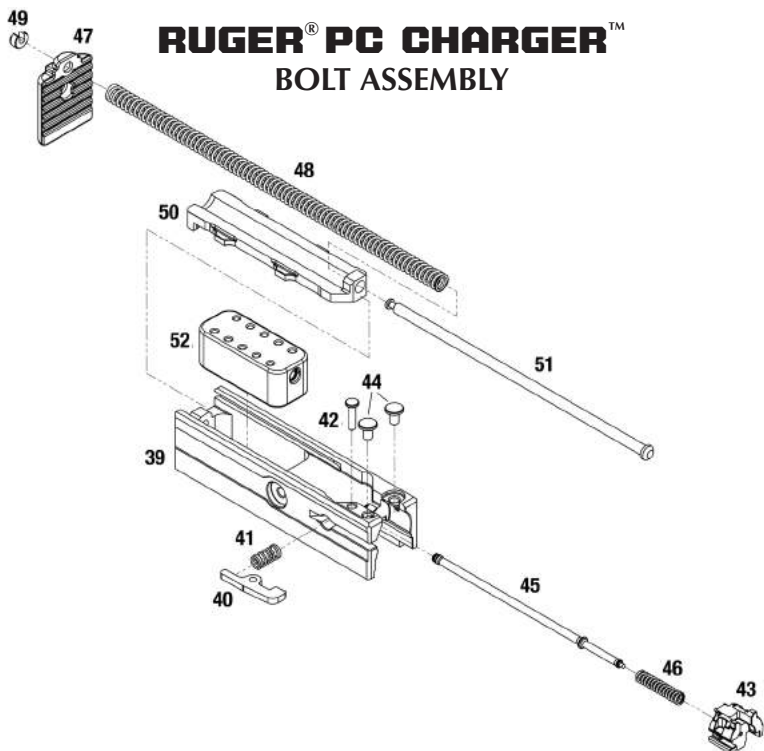

RUGER® PC CHARGER™
BARREL/HANDGUARD ASSEMBLY

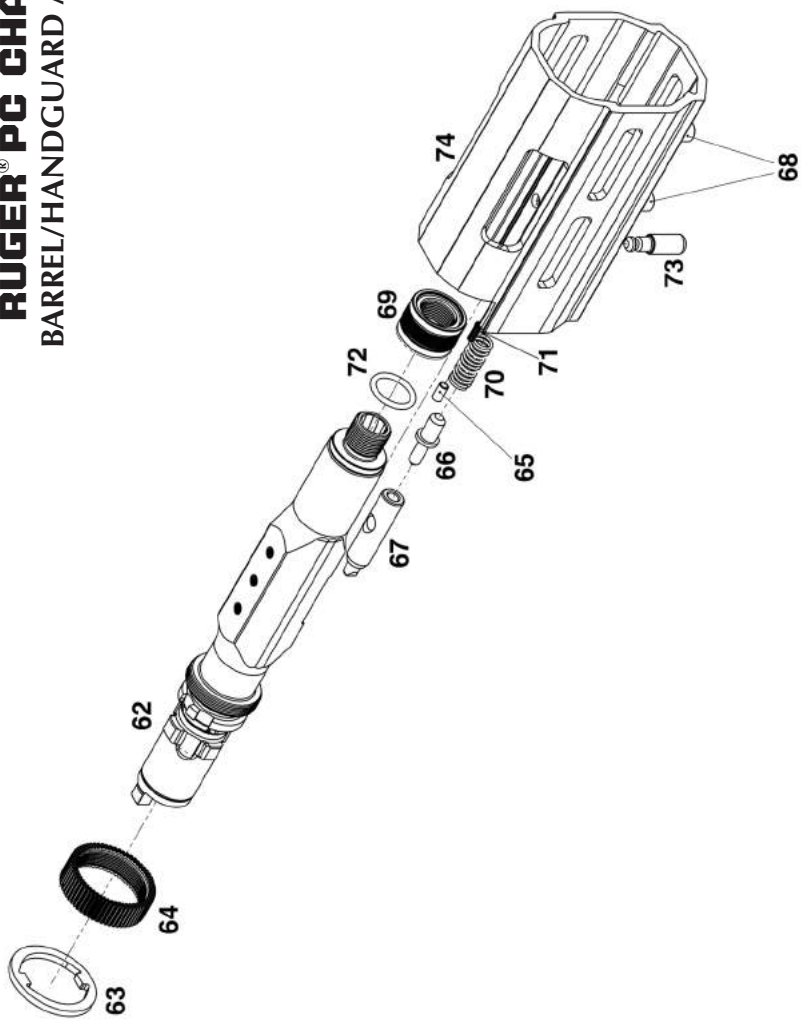

THE BASIC RULES OF SAFE FIREARMS HANDLING

We believe that Americans have a right to purchase and use firearms for lawful purposes. The private ownership of firearms in America is traditional, but that ownership imposes the responsibility on the gun owner to use his firearms in a way which will ensure his own safety and that of others. When firearms are used in a safe and responsible manner, they are a great source of pleasure and satisfaction, and represent a fundamental part of our personal liberty.

Firearms do not cause accidents! Firearms accidents are almost always found to have been the result of carelessness or ignorance on the part of the shooter of the basic rules of safe gun handling.

The following rules must be observed by gun users at all times. Safe gun handling is not just desirable, it is absolutely essential to your safety, the safety of others, and the continuation of gun ownership and sport shooting as we know it today.

1. LEARN THE MECHANICAL AND HANDLING CHARACTERISTICS OF THE FIREARM YOU ARE USING.

Not all firearms are the same. The method of carrying and handling firearms



varies in accordance with the mechanical provisions for avoiding accidental discharge and the various proper procedures for loading and unloading. No person should handle any firearm without first having thoroughly familiarized himself with the particular type of firearm he is using, and with safe gun handling in general.

2. ALWAYS KEEP THE MUZZLE POINTED IN A SAFE DIRECTION.



Be sure of the bullet stop behind your target, even when dry-firing. Never let the muzzle of a firearm point at any part of your body or at another person. This is particularly important when loading or unloading a firearm. In the event of an accidental discharge, no injury can occur as long as the muzzle is pointing in a safe direction. A safe direction means a direction that will not permit a discharged bullet to strike a person, or to strike an object from which the bullet may ricochet.

A safe direction must take into account the fact that a bullet may penetrate a wall, ceiling, floor, window, etc., and strike a person or damage property. Make it a habit to know exactly where the muzzle of your gun is pointing whenever you handle it, and be sure that you are always in control of the direction in which the muzzle is pointing, even if you fall or stumble. Keep your finger off the trigger until you are ready to shoot.

3. FIREARMS SHOULD BE UNLOADED WHEN NOT IN USE.

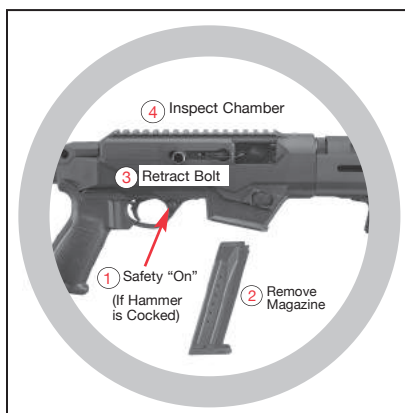

Firearms should be loaded only when you are in the field or on the target range or shooting area, ready to shoot. Firearms and ammunition should be securely locked in safes, racks or cabinets, or by using the locking device supplied with the firearm, when not in use.

Ammunition should safely be stored separate from firearms. Store your firearms out of sight of visitors and children. It is the gun owner's responsibility to be certain that children and persons unfamiliar

with firearms cannot gain access to firearms, ammunition, or components.

4. BE SURE THE BARREL IS CLEAR OF OBSTRUCTIONS BEFORE SHOOTING.

Even a bit of mud, snow or excess lubricating oil or grease in the bore may cause the barrel to bulge, or even burst on firing, and can cause serious injury to the shooter and bystanders. Be sure that you are using ammunition of the proper caliber and loading for the gun you are using. If the report or recoil on firing seems weak, or doesn't seem quite right, CEASE FIRING IMMEDIATELY, unload your firearm, and check to be sure that no obstruction has become lodged in the barrel. Never try to shoot out an obstruction!





5. BE SURE OF YOUR TARGET BEFORE YOU SHOOT.

Don't shoot unless you know exactly where your bullet is going to strike. Be sure of the bullet stop behind your target, even when dry-firing with an unloaded gun. If you are in the field hunting, do not fire at a movement or noise. Take the time to be absolutely certain of your target before you pull the trigger.

6. WEAR SHOOTING GLASSES AND HEARING PROTECTION WHEN YOU SHOOT.

All shooters should wear protective shooting glasses and adequate hearing protection when shooting. Exposure to shooting noise can damage hearing, and wearing adequate eye protection when shooting is essential.



7. NEVER CLIMB A TREE OR FENCE WITH A LOADED FIREARM.

Put the firearm down carefully before climbing a fence, and unload it before climbing or descending a tree or jumping over a ditch or other obstruction. Never pull or push a loaded firearm toward yourself or another person. When in doubt, or whenever you are about to do anything awkward, unload your gun!

8. DON'T SHOOT AT A HARD SURFACE OR AT WATER.

Bullets can glance off many surfaces like rocks or the surface of water and travel in unpredictable directions with considerable velocity.



9. NEVER TRANSPORT A LOADED FIREARM.

Firearms should always be unloaded before being placed in a vehicle. A suitable carrying case or scabbard should be used to carry an unloaded firearm to and from the shooting area.

10. AVOID ALCOHOLIC BEVERAGES WHEN SHOOTING.

Don't drink until the day's shooting is over. Handling firearms while under the influence of alcohol in any form, or medications that could affect your judgment or coordination, constitutes a criminal disregard for the safety of others.



A BRIEF ACCOUNT OF AN EXTRAORDINARY ACHIEVEMENT: RUGER® FIREARMS

Sturm, Ruger & Company, Inc., had its beginning in a small machine shop occupying a rented frame building in Southport, Connecticut. In January, 1949, with an initial investment of only \$50,000 and an idea, William B. Ruger and Alexander M. Sturm started production of a .22 caliber autoloading pistol—a design which was so successful that it became the cornerstone upon which one of the most comprehensive lines of sporting firearms ever made in America was established. After Alex Sturm's death in 1951, William B. Ruger continued to direct the Company until his death in 2002. William B. Ruger, Jr. continued to provide guidance, which helped make this Company a sound and successful enterprise, until his retirement in 2006. The Company has continued to prosper, under new management and guidance from our Board, with new products and fresh perspectives.

Ruger, in this relatively short time, has established itself as a leading small arms design organization, developing a unique and broad line of fine quality sporting, military and police firearms to become one of the world's most famous producers of revolvers, pistols, rifles and shotguns. Since 1949, Ruger craftsmen have built many millions of firearms.

During its six decades of growth and progress under the leadership of William B. Ruger, the Company developed a business philosophy and implemented policies which represent a constructive influence in the life of modern America. From the beginning, Ruger played a positive role in conservation efforts and has supported the interests of shooters through such groups as the National Rifle Association, National Shooting Sports Foundation, and many regional sportsmen's organizations.

The Company has always endeavored to market its firearms for constructive and recreational purposes, to emphasize the traditional and responsible aspects of shooting, to render meaningful public services, and to encourage shooters in constructive, responsible, and safe participation in the shooting sports. Its motto, "Arms Makers For Responsible Citizens®," exemplifies this Company philosophy.

Today, Ruger® is particularly mindful of those elements which have contributed to the creation of its success, and extends heartfelt thanks to its many loyal employees and customers.

Instruction manuals for all Ruger® firearms,
can be downloaded from our website at:

Ruger.com

NOTES

WHY NO WARRANTY CARD HAS BEEN PACKED WITH THIS NEW RUGER® FIREARM

The Magnuson-Moss Act (Public Law 93-637) does not require any seller or manufacturer of a consumer product to give a written warranty. It does provide that if a written warranty is given, it must be designated as "limited" or as "full" and sets minimum standards for a "full" warranty. Sturm, Ruger & Company, Inc. has elected not to provide any written warranty, either "limited" or "full", rather than to attempt to comply with the provisions of the Magnuson-Moss Act and the regulations issued thereunder. There are certain implied warranties under state law with respect to sales of consumer goods. As the extent and interpretation of these implied warranties varies from state to state, you should refer to your state statutes. Sturm, Ruger & Company wishes to assure its customers of its continued interest in providing service to owners of Ruger® firearms.



STURM, RUGER & Company, Inc.
411 Sunapee Street
Newport, New Hampshire 03773 U.S.A.
Ruger.com

Arms Makers For Responsible Citizens®

**A COPY OF THE INSTRUCTION MANUAL FOR ANY RUGER®
FIREARM IS AVAILABLE FROM THE FACTORY FREE ON REQUEST, OR IT MAY BE
DOWNLOADED FROM OUR WEBSITE AT RUGER.COM.
THESE INSTRUCTION MANUALS CONTAIN IMPORTANT
WARNINGS WHICH MUST BE UNDERSTOOD
BEFORE USING THESE FIREARMS.**

The Following are Sturm, Ruger & Co., Inc. Trademarks: "All-Weather," "Bisley," "Gold Label," "I'm a Ruger American," "LC6," "LCR-357," "LC380CA," "Mark II," "Mark III," "Mark IV," "MAX-9," "Model 96," "P345," "P345D," "P345PR," "P85," "P89," "P90," "P91," "P93," "P94," "P95," "P97," "PC Carbine," "R.I.O.S.," "Ruger-5.7," "Ruger Marksman Adjustable," "Ruger 77/50," "Ruger 10/17," "Security-Six," "Service-Six," "77/357," "Single-Seven," "Speed-Six," "SR45," "SR-556C," "SR-556VT," "Super Bearcat," "Target Grey," "10/22-FS," "This is Ruger. This is America," "Tri-Flex," "22 Charger," "22/45," "22/45 RP," and "Your Next Handgun."

The Following are Registered U.S. Trademarks Belonging to Sturm, Ruger & Co., Inc.: "AC-556," "AR-556," "Arms Makers For Responsible Citizens," "Bearcat," "Blackhawk," "BX-15," "BX-25," "BX-Trigger," "Eagle - solid logo design, Eagle Hard 'R' logo holding gun, Eagle 'R' - soft 'R' & hard 'R' logo design, Eagle w/'SR', Eagle w/soft 'R' linear logo design, Eagle w/hard 'R' linear logo design, Eagle w/soft 'R' stacked logo design, Eagle w/hard 'R' stacked logo design, Eagle w/soft 'R' linear logo design & "Rugged, Reliable Firearms" below logo, Eagle w/hard 'R' linear logo design & "Rugged, Reliable Firearms" below logo, "EC9s," "Elite 452," "GP100," "Hawkeye," "It's Mine and It's American," "It's Mine. And It's American," "LC380," "LC9," "LC9s," "LC9s Pro," "LCP," "LCR," "LCRx," "M77," "Match Champion," "Mini-14," "Mini Thirty," "9E," "Old Army," "Power Bedding," "Redhawk," "RUGER," "Ruger American," "Ruger American Pistol," "Ruger American Pistol" flag design, "Ruger American Rifle," "Ruger American Rimfire," "Ruger Custom Shop," "Ruger Hunting" - phrase & logo design, "Ruger Precision," "Ruger Precision Rifle" - phrase & logo design, "Ruger 77/17," "Ruger 77/22," "Ruger 77/44," "Ruger SP101," "Ruger 10/22 Takedown" phrase & logo design, "Ruger Titanium," "Ruger 22/45 Lite," "Ruger Vaquero," "Rugged, Reliable Firearms," "Security-9," "Silent-SR," "Single-Nine," "Single-Six," "Single-Ten," the "SR" Design, "SR9," "SR9c," "SR40," "SR40c," "SR-22," "SR22," "SR-556," "SR-556 Takedown," "SR-762," "SR1911," "Super Redhawk Alaskan," "10/22," & "Wrangler."